



ELEMENT CARBON

-ENG-FR-GER- IT

Riders:
Celeste Pomerantz

Photo:
Niklas Wallner

Location:
Norway

REGISTER / ENREGISTRER / REGISTRA / REGISTRIERE

Registering your bike is the official way for us to welcome you into the Rocky Mountain family. It's also an important step in activating your bike's warranty. If you ever have an issue, we'll be able to handle your case efficiently and get you back riding as soon as possible. It's easy and only takes a few minutes.

Register your bike: bikes.com/register

L'enregistrement de votre vélo marque votre entrée officielle dans la famille Rocky Mountain, et c'est une étape importante pour en activer la garantie. Ainsi, en cas de problème, nous pourrions le régler efficacement pour vous faire remonter en selle aussitôt que possible. L'enregistrement est facile et ne prend que quelques minutes.

Enregistrer votre vélo : bikes.com/register

La procedura di registrazione della tua bicicletta è il modo ufficiale di accoglierti nella famiglia Rocky Mountain. È inoltre una tappa importante per attivare la garanzia della tua bicicletta. Nel caso in cui si verificasse un problema, potremo gestire il tuo caso in maniera efficiente e farti risalire in sella il più presto possibile. La procedura di registrazione è semplice e richiede solo alcuni minuti.

Registra la tua bicicletta: bikes.com/register

Wenn du dein Bike registrierst, können wir dich offiziell in der Rocky Mountain Familie willkommen heißen. Es ist auch ein wichtiger Schritt für die Aktivierung der Garantie deines Bikes. Solltest du irgendwann ein Problem haben, können wir deinen Fall effizient bearbeiten und dich schnellstmöglich wieder auf dein Bike bringen. Es ist einfach und dauert nur ein paar Minuten.

Registrierte dein Bike: bikes.com/register



TABLE OF CONTENTS

Introduction	4
Shrediquette	4
Getting to know your bike	5
Geometry & Sizing	6
Specification & Dimensions	12
UDH Hanger	13
Shock Bearing eyelet & Hardware	13
Suspension Setup	15
Cable Routing How-To	19
Critical Dimensions	24
Parts List & Exploded View	26
Warranty information	29

INHALTSVERZEICHNI

Einleitung	58
Mountainbike-Knigge	58
Erne dein Bike kennen	59
Geometrie und Grössen	60
Spezifikationen und Abmessungen	66
UDH Schaltauge	67
Eyeletbearing Und Dämpferhardware	68
Dämpferabstimmung	69
Zugverlegung How-to	73
Wichtige Abmessungen	78
Explosionszeichnung	80
Garantieinformationen	83

TABLE DES MATIÈRES

Introduction	31
Étiquette de la montagne	31
Survol de votre vélo	32
Géométrie et taille	33
Spécifications et dimensions	39
Support de dérailleur universel	40
Quincaillerie	41
Configuration de la suspensions	42
Passage des câbles	46
Guide des dimensions	51
Vue explosée	53
Liste complète des pièces	54
Garantie	56

INDICE

Introduzione	85
Shrediquette	85
Conoscere la tua bicicletta	86
Geometria e dimensione	87
Specifiche e dimensioni	93
Forcellino UDH	94
Occhiello E Minuteria Cuscinetti ammortizzatore	95
Configurazione delle sospensioni	96
Istruzioni per il passaggio dei cavi	100
Dimensioni critiche	105
Esplosa	107
Informazioni sulla garanzia	110

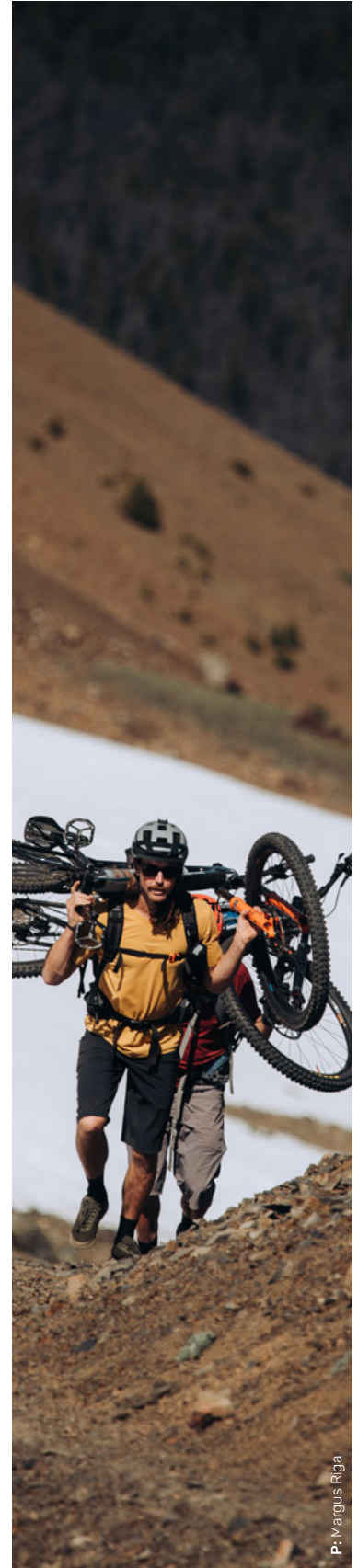

INTRODUCTION

The Element is all about efficiency—you'll be inspired to sprint the climbs then surprised by your pace on the descents. Designed to be more capable and handle technical singletrack better than ever before, the Element strikes a balance between weight, stiffness and comfort. The updated Smoothlink SL suspension design and frame details promote riding with precision, making the Element the perfect bike for those racing the clock, chasing a friend, or just heading out for another long day in the saddle.

This manual contains important safety, maintenance, and user information. Read and understand it thoroughly before your first ride on your new Rocky Mountain bicycle. This material applies only to the specific platform you have chosen and should be used in conjunction with your Rocky Mountain Owner's Manual, which is included with your bike. Please read the Owner's Manual before your first ride. If you do not have a copy of the Owner's Manual, you can get it from your nearest authorized Rocky Mountain dealer.

SHREDIQUETTE

Riders

Always be courteous to other trail users. Use extra caution around domestic animals, such as dogs and horses. Give other trail users right-of-way in all situations, during both climbing and descending.

Trails

Only ride your bicycle on trails and paths sanctioned for bicycle use. Follow all local laws and regulations. As for all trail users, care should be taken to avoid impacts on the trail or environment. Do not skid on or modify trails.

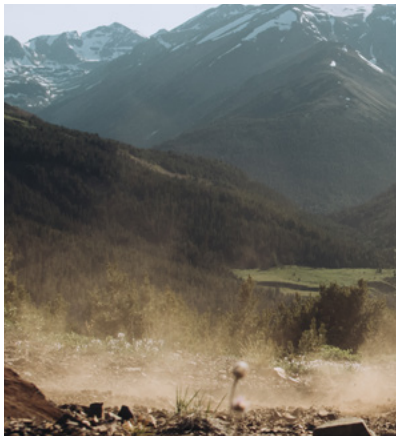
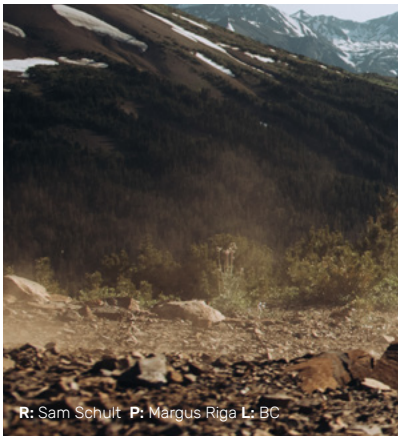

GETTING TO KNOW YOUR BIKE



TECHNICAL DETAILS

- The updated Element features an all-new frame design with our new flex stay rear triangle that increases stiffness and dramatically reduces frame weight.
- All new Smoothlink SL kinematic features sensitivity paired with increased support throughout the travel, with a goal of increasing stiffness for better power transfer.
- The progressive geometry and thoughtful frame features remain ensuring a familiar, high-performance experience over the highly praised previous generation.
- Offered in a wide range of frame and wheel sizes. The XS frame is equipped with 27.5" front and rear wheels. The MD-LG-XL frames are equipped with 29" front and rear wheels. This platform is not intended to work with mullet, MX adjustment.
- The RIDE-4™ adjustment system allows riders to quickly fine-tune their geometry with a single Allen key.
- Sealed bearings at the shock eyelet dramatically improve shock sensitivity and are compatible with all shocks.
- Our Smoothlink SL suspension features a flex stay rear triangle that removes the bearing equipped pivot at the dropouts. We then upgraded the seat stay-link pivot with more durable dual-row bearings, and use common, easy to service bearings for ease of service.
- There are bearing shields throughout, including sealed washers at the main pivot, to help prevent contamination from gnarly trail conditions or post-ride wash stations.
- The fully enclosed internal routing on our carbon models and large open ports on alloy allow for easy cable and hose installations, including moto-style brake setups.
- The main pivot nut is interchangeable with the one on the Element to accept our Canadarm OneUp chain guide.
- The frame features a complete protector package with our silent rubber chainstay, seatstay, and downtube protectors.
- All frame sizes, except the XS, are compatible with two water bottles inside the front triangle. The lower bottle mount features two mounting positions to optimize placement if a single bottle is preferred.

GEOMETRY & SIZING

The Element is a size-specific frame design that features many details that improve the fit and geometry for each rider.

Wheel size

- The XS frame is equipped with 27.5" wheels front and back.
- The SM, MD, LG, and XL frames are equipped with 29" wheels front and back.
- This platform is not intended to be compatible with mullet/MX adjustments.

Ride-4

The RIDE-4™ adjustment system allows riders to quickly fine-tune their geometry with a single 5-mm Allen key. Four configurations are possible thanks to a pair of rotating chips. Please see the geometry chart for how each position affects the geometry. For adjustment instructions, please see the Frame Features section.

READY FOR ANY TRAIL

The RIDE-4™ adjustment system allows you to quickly fine-tune your geometry and suspension with a single 5-mm Allen key.

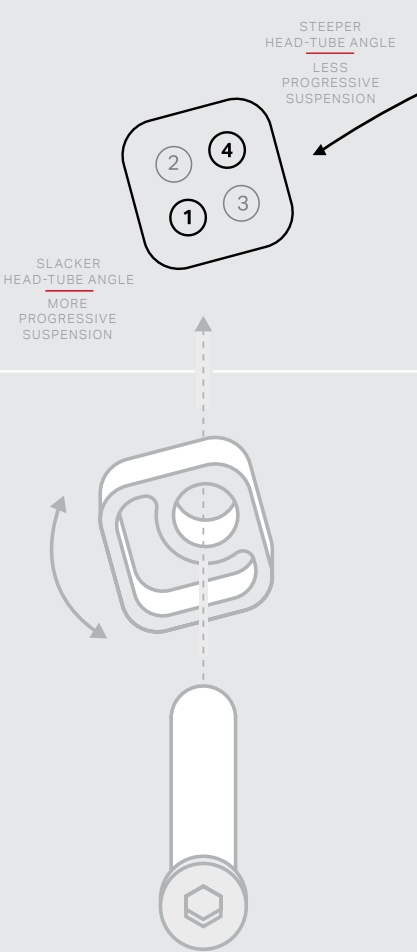



Diagram labels:

- Position 1: SLACKER HEAD-TUBE ANGLE, MORE PROGRESSIVE SUSPENSION
- Position 2: SLACKER HEAD-TUBE ANGLE, MORE PROGRESSIVE SUSPENSION
- Position 3: STEEPER HEAD-TUBE ANGLE, LESS PROGRESSIVE SUSPENSION
- Position 4: STEEPER HEAD-TUBE ANGLE, LESS PROGRESSIVE SUSPENSION



Position 1

 SLACK

The lower bottom bracket and progressive suspension increase stability at higher speeds. Recommended for more aggressive trail riding

Position 3

 NEUTRAL

This position offers a balanced blend of geometry and suspension performance to cater to a wide variety of trails

Position 4

 STEEP

The higher bottom bracket and linear suspension allow for better pedal clearance, a more supportive initial suspension rate, and a position on the bike better suited for climbing.

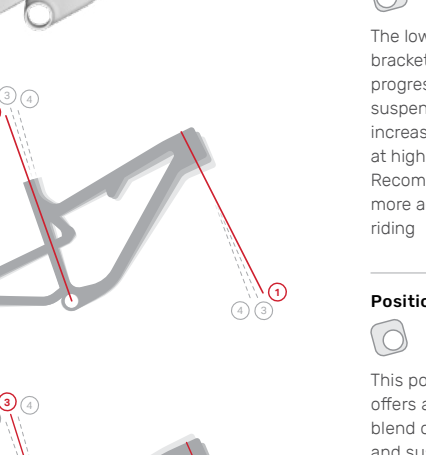

GEOMETRY & SIZING

Frame Sizing

This chart is a rough guide only. Rider proportions, riding style, and personal preferences all factor in choosing the correct bike size. Generally, shorter reach bikes tend to have a more dynamic, lively feel. Longer bikes tend to have a more stable, muted feel. Rocky Mountain always recommends test riding and professional bike fitting at an authorized dealer.

CM	147,5	150	152,5	152,5	155	157,5	160	162,5	165	167,5	170	172,5	175	177,5	180	183	185,5	188	190,5	193	195,5	198		
FT-IN	4'7"	4'8"	4'9"	5'0"	5'1"	5'2"	5'3"	5'4"	5'5"	5'6"	5'7"	5'8"	5'9"	5'10"	5'11"	6'	6'1"	6'2"	6'3"	6'4"	6'5"	6'6"		
			XS				SM				MD				LG				XL					
XS	█																							
SM				█																				
MD							█																	
LG										█														
XL																█								



R: Celeste Pomerantz P: Niklas Wallner L: Norway

GEOMETRY CHART

FRAME SIZE	XS	SM	MD	LG	XL
Wheel size	27.5			29	
Head Tube Angle (deg)	64,7	65	65	65	65
Seat Tube Angle (deg)	75,7	76	76	76	76
Seat Tube Length (mm)	355	380	420	445	480
Top Tube Length (mm)	542	577	605	632	664
Head Tube Length (mm)	90	105	115	125	135
Rear Center (mm)	Position 1 Slack	426	436	436	436
Bottom Bracket Drop (mm)		28	47	47	47
Standover Height (mm)	769	810	808	806	804
Wheelbase (mm)	1127	1173	1202	1231	1265
Reach (mm)	397	425	450	475	505
Stack (mm)	561	606	615	624	633

Head Tube Angle (deg)	64,9	65,2	65,2	65,2	65,2
Seat Tube Angle (deg)	75,9	76,2	76,2	76,2	76,2
Seat Tube Length (mm)	355	380	420	445	480
Top Tube Length (mm)	542	577	604	631	663
Head Tube Length (mm)	90	105	115	125	135
Rear Center (mm)	Position 2	426	435	435	435
Bottom Bracket Drop (mm)		26	43	43	43
Standover Height (mm)	770	811	809	807	805
Wheelbase (mm)	1127	1173	1202	1231	1265
Reach (mm)	400	427	452	477	507
Stack (mm)	563	607	616	625	635

GEOMETRY CHART

FRAME SIZE	XS	SM	MD	LG	XL
Wheel size	27.5			29	
Head Tube Angle (deg)	65,3	65,5	65,5	65,5	65,5
Seat Tube Angle (deg)	76,1	76,5	76,5	76,5	76,5
Seat Tube Length (mm)	355	380	420	445	480
Top Tube Length (mm)	541	576	603	631	663
Head Tube Length (mm)	90	105	115	125	135
Rear Center (mm)		Position 3 Neutral			
Bottom Bracket Drop (mm)	425	435	435	435	435
Standover Height (mm)	21	40	40	40	40
Wheelbase (mm)	771	812	810	809	807
Reach (mm)	1127	1173	1202	1231	1265
Stack (mm)	403	430	455	480	510
	565	609	618	627	636
<hr/>					
Head Tube Angle (deg)	65,5	65,8	65,8	65,8	65,8
Seat Tube Angle (deg)	76,5	76,8	76,8	76,8	76,8
Seat Tube Length (mm)	355	380	420	445	480
Top Tube Length (mm)	541	575	603	630	662
Head Tube Length (mm)	90	105	115	125	135
Rear Center (mm)		Position 4 Steep			
Bottom Bracket Drop (mm)	425	435	435	435	435
Standover Height (mm)	19	36	36	36	36
Wheelbase (mm)	772	813	811	810	808
Reach (mm)	1127	1173	1202	1231	1265
Stack (mm)	405	433	458	483	513
	566	610	619	628	637

GEOMETRY & SIZING

Dropper Seatpost Fitment

Dropper seatposts have play an important role in bike fit and comfort. Below you will find the critical dimensions and measurements that will guide you in the OEM post configuration as well as some of the possible options if an aftermarket dropper seatpost is installed.

The chart shows seatpost fitment with the seatpost travel fully extended. This allows you to determine what the lowest or highest position your seatpost can be set at for the correct height in a seated pedalling position. The chart will also help guide you in determining the size seatpost to install if the OEM one isn't the desired size. Please note that the dimension listed is from the center of the BB to the top of the OEM saddle. Crankset length can influence the seated fit and should also be considered if that component is changed.

How to use the chart

1. Measure your current saddle height from the center of the bottom bracket to the top of the saddle right above the seatpost.
2. Choose your desired post model and amount of post travel/drop and frame.
3. Ensure that your measurement falls between the minimum and maximum insertion length listed in the chart.

Example: I measured 795mm on my current bike. If I choose a OneUp V3, 210mm travel option, on a LG Carbon frame, I can see that I can fit this combination of post travel and frame size as the minimum and maximum measurements possible are 728mm to 860mm.

POST MODEL	OEM SPEC PER FRAME SIZE	POST TRAVEL	FRAME SIZE	CARBON					
				XS	SM	MD	LG	XL	
X Fusion Manic	XS - SM	125	Seat Tube Length	355	380	420	445	480	
			Minimum Insertion	100	100	100	100	100	
		Maximum Insertion	200	200	230	260	280		
		Minimum saddle height	599	624	640	665	700		
	MD	125	Maximum saddle height	671	696	736	761	796	
		150	Minimum saddle height	663	688	698	693	725	
	LG	150	Maximum saddle height	725	750	790	815	850	
		170	Minimum saddle height	707	732	742	737	752	
	XL	170	Maximum saddle height	739	764	804	829	864	
		200	Minimum saddle height	772	797	807	802	817	
		200	Minimum saddle height	784	809	849	874	909	
2025 Fox Transfer *Travel is adjustable and can be reduced up to 25mm, in 5mm increments	XS - SM	120	Seat Tube Length	574	599	621	646	681	
			Minimum Insertion	646	671	711	736	771	
	MD	150	Maximum Insertion	639	664	674	677	712	
		150	Minimum saddle height	711	736	776	801	836	
	LG	180	Maximum saddle height	704	729	739	734	749	
		180	Minimum saddle height	776	801	841	866	901	
	XL	210	Maximum saddle height	769	794	804	799	814	
		200	210	Minimum saddle height	841	866	906	931	966

GEOMETRY & SIZING

POST MODEL	"OEM SPEC PER FRAME SIZE"	POST TRAVEL	FRAME SIZE	CARBON				
				XS	SM	MD	LG	XL
Reverb AXS *min post insertion is 80mm, however frame requires 100mm	XS - SM	125	Seat Tube Length	587	612	652	677	712
		125	Minimum Insertion	687	712	752	777	812
	MD	150	Maximum Insertion	637	662	677	702	737
		150	Minimum saddle height	737	762	802	827	862
	LG - XL	175	Maximum saddle height	687	712	722	727	762
		175	Maximum saddle height	787	812	852	877	912
OneUp V3 Dropper *Travel is adjustable and can be reduced up to 20mm, in 10mm increments	XS - SM	120	Seat Tube Length	560	585	625	650	685
		120	Minimum Insertion	645	670	710	735	770
	MD	150	Maximum Insertion	620	645	655	675	710
		150	Minimum saddle height	705	730	770	795	830
	LG	180	Maximum saddle height	680	705	715	710	735
		180	Minimum saddle height	750	775	815	840	875
	XL	210	Maximum saddle height	740	765	775	770	785
		210	Minimum saddle height	795	820	860	885	920
		240	Maximum saddle height	810	835	845	840	855
		240	Minimum saddle height	850	875	915	940	975
Revive 3 Dropper *Travel is adjustable and can be reduced up to 30mm, travel option dependant, in 5mm increments		125	Seat Tube Length	581	606	627	652	687
		125	Minimum Insertion	680	705	745	770	805
		160	Maximum Insertion	651	676	686	687	722
		160	Minimum saddle height	730	755	795	820	855
		185	Maximum saddle height	701	726	736	731	747
		185	Minimum saddle height	780	805	845	870	905
		213	Maximum saddle height	766	791	801	796	811
		213	Minimum saddle height	815	840	880	905	940

SPECIFICATIONS AND DIMENSIONS

ZS44|56 Press-In Headset

All frames are equipped with ZS44|56 Press-In headsets

The Carbon Element frame uses press-in style headset cups. Specialized headset tools are required to remove and install the cups in the frame. The headsets for the carbon frames are manufactured by FSA and are often identified as the No.57e or Orbit 1.5zs model. They use standard FSA assembly parts such as bearings and races to ensure that replacing wear items are a painless process.

Assembly Element Carbon - Alloy Headset

Notes The Element uses a stainless bearing, 5.3mm top cap equipped variation of the common No.57e / Orbit 1.5ZS FSA headset.

QTY	ITEM	PART NUMBER	DESCRIPTION
1	Headset	121-0501	FSA Part Number No.57E - Orbit 1.5ZS Headset with standard bearings and 8mm top cap
1	Headset	H018200000E401	FSA Part Number No.57E - Orbit 1.5ZS Headset with stainless bearings and 5.3mm top cap
2	Upper Headtube	N/A	ZS44 Standard
N/A	Lower Headtube	N/A	ZS56 Standard
1	Rubber O-Ring	160-7042	FSA Top Cap Inner Rubber O-Ring
1	Top Cap	161-4430	FSA 5.3mm Top Cap inc. rubber seal
1	Split Race	160-7626	FSA 1 1/8" Headset Compression Ring
1	Bearing	160-6465	FSA Stainless ACB 1 1/8" 36°x45° Bearing
1	Bearing	160-67400E	FSA Stainless ACB 1.5" 36°x45° Bearing
1	Crown Race	160-5536	FSA 1.5" Crown Race

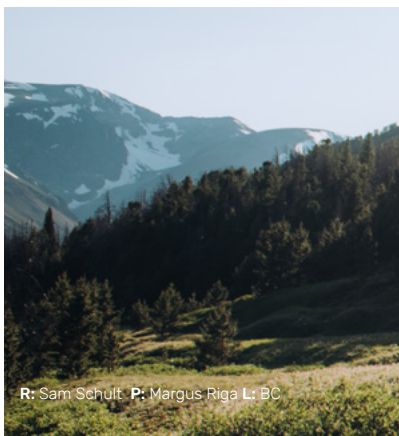

R: Sam Schult. P: Margus Riga L: BC

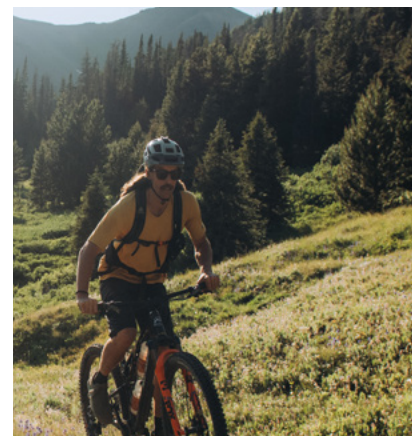
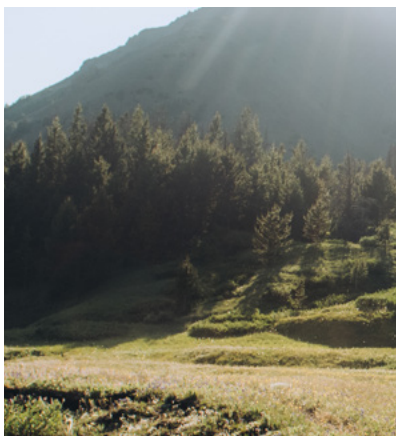

UDH HANGER

Your new frame is compatible with Sram’s UDH hanger. There are no special instructions related to the frame that are required for the installation of a UDH hanger. For proper Sram UDH installation, please consult the Sram instructions provided with their hanger.

SHOCK BEARING EYELET AND HARDWARE

Your frame is equipped with cartridge bearings in the rear eyelet, allowing for better small-bump compliance. These bearings are carried by cups that have a very firm press fit into the shock shaft. If you have your shock serviced, we highly recommend removing these components, as suspension service centres cannot guarantee they will be returned.

The forward shock hardware is a standard kit provided by the shock manufacturer. Please see the chart below for technical information on all shock hardware, diagrams for reference, and instructions for removing the bearing eyelet system.

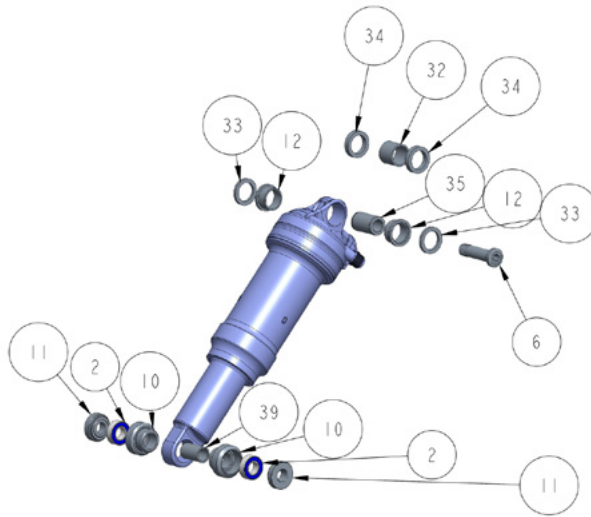

Assembly *Element Forward Shock Hardware*
 Dimensions *20x8mm (Shock Pin Width x Hardware Diameter)*

QTY	ITEM	PART NUMBER	DESCRIPTION
1	Fox Complete Kit	803-03-326	FOX Mounting Hardware - 9 Piece AL 8mm x 20/0.787"
1	Rock Shox Complete Kit	11.4118.091.806	ROCK SHOX HARDWARE 8 x 20.0

Pro Tip: Fox Complete Kit is compatible with Rock Shox shocks eyelets. Remove the teflon bushing from the Rock Shox eyelet before installing the Fox kit.

SHOCK BEARING EYELET AND HARDWARE

Bearing Eyelet Removal

To remove the system, follow these steps

- Use the Rocky Mountain Bearing Eyelet Tool Kit (Part# 1810031)
- Install the top hat piece on one side of the bearing eyelet
- Next, install one of the cup removal tools over the bearing cup with the top hat piece installed.
- Thread the M8 screw snugly against the top hat piece.
- Install the other cup removal tool over the other bearing cup.
- Thread the M8 screw all the way in until it starts pushing on the other side. It is contacting the inside of the top hat piece.
- Keep threading until one of the cups is fully pushed out.
- Next insert the drift tool through the shock eyelet and rest it firmly against the bearing cup that is still pressed in the shock eyelet.
- Gently, but firmly, hammer the drift tool until the bearing cup is fully removed from the shock eyelet.

If you do not have the Rocky Mountain Bearing Eyelet Tool Kit, use a blind bearing puller:

- Use a blind bearing puller (8 mm extension) to remove both bearings. Install the top hat piece on one side of the bearing eyelet
- Remove the centre sleeve.
- Use the blind bearing puller (10 mm extension) to remove the empty cups.

NOTE: the inner diameter of the cups is 11 mm, which means the 12 mm extension won't fit (So don't force it); Use the 10 mm extension.

To install new cups, use a bearing press or vice with soft jaws installed, making sure to press on the outer edge of the cups, and don't forget the centre spacer sleeve between the cups.

SUSPENSION SETUP

Before changing your shock settings, it's important to educate yourself about the various adjustments that can be made.

Spring Adjustment

Depending on the shock model, you may need to adjust the coil spring rate or air pressure to achieve the recommended sag for Instinct. Consult the spring chart below for recommendations on coil spring rates and air pressures.

Rebound

Rebound adjustment controls how quickly your suspension returns to full extension after it hits a bump. Too much rebound control, and the fork or shock will move too slowly, sinking deeper and deeper into its travel under repeated hits, which will feel harsh. Too little, and the suspension can spring back too quickly, causing a loss of traction and control.

- Low Speed Rebound (LSR) refers to low fork or shock speed, not trail speed. This adjustment affects rebound rate in the first portion of the travel. For the sake of bracketing, we can assume from 0% to 40% travel.
- High Speed Rebound (HSR) refers to high fork or shock speed, not trail speed. This adjustment affects rebound rate in the second portion of the travel. For the sake of bracketing, we can assume from 40% to 100% travel.

Compression

Compression adjustment controls how quickly your suspension moves into its travel as it hits a bump. Too much compression control and the fork or shock will move too slow and the force of the impact will rely too much on the tire and your body to absorb the movement. Too little compression and the fork or shock will move too quickly making the bike feel sluggish and unresponsive.

Low speed compression (LSC) refers to low fork or shock speed, not trail speed. It controls rider weight shifts, pumping through terrain, G-outs, and other slow inputs. Too much LSC will result in a harsher ride feel; too little LSC will result in a ride feel that's too soft and unresponsive. LSC is effective throughout the entire range of travel.

High speed compression (HSC) refers to high fork or shock speed, not trail speed. It controls the ability to absorb large impacts such as square edge rocks and bottom outs. Too much HSC will result in a harsher ride feel when riding fast, rough trails with many large bumps; too little HSC will result in not enough support when hitting those large bumps and might result in using all your suspension travel.

Hydraulic bottom out

Hydraulic Bottom Out (HBO) refers to the bottom out resistant that some shocks can provide in combination with an external adjuster. This affects the last 20% of the shock travel and it used for large impacts where the bike can bottom out.

SUSPENSION SETUP

Please see below tables for all OEM shock configurations for the Instinct. Due to the large number of shocks compatible with the Instinct, we cannot provide setup guides for models outside of the OEM specifications.

Suspension tips and tricks

When tuning your suspension, write down your settings so you can refer back to them. Better yet, use an online spreadsheet on your phone!

Removing the shock on the Element with its Smoothlink SL suspension design is easy but can require a few tips and tricks. The main difference with our Smoothlink SL rear triangle and its one-piece design is the seats are designed to be static and provide 0 spring force at 25% sag. When you remove the shock, the rear triangle will want to move back to its natural position of rest. Reinstalling the shock requires a small amount of flex to occur to get all the last remaining bolt, whether at the seat stay pivot or shock mount, to line up.

Here's a step-by-step guide on removal. Shift down to the small cog on the cassette and lock the derailleur cage open if possible.

1. Place shock in the link
 - a. The bearing eyelet spacers on each side will fall away, so be sure that you place a hand below the bearing eyelet area to keep them in place.
2. Insert rear shock bolt.
 - a. If required, you can remove the Ride4 chips on both sides of the link to get the bolt to line up with the bearing eyelet first. Once the bolt is half inserted into the bearing eyelet, lining up the Ride4 chip will be a much easier task.
3. Install forward shock bolt.
 - a. This step requires you to gently preload the rear triangle until the forward shock eyelet lines up with the shock mount hole.
4. Once both shock bolts are installed and partially threaded, add some preload to the rear triangle to ensure all hardware is settled into place and tighten down both bolts.
5. Torque all hardware to spec. Please see our exploded diagram for details.

Assembly *Element Rear Shock Bearing Eyelet*
Dimensions *40x8mm (Width x Hardware Diameter)*

QTY	ITEM	PART NUMBER	DESCRIPTION
QTY	Item	Part Number	Description
1	RMB Complete Kit	1811007	8 x 40mm Shock Bearing Eyelet Kit
2	Bearing	1801010	ENDURO 688 LLU MAX 16X8X5
2	Bearing Cup	1800031	BEARING EYELET FOR 16X8X5 BRG
1	Sleeve	1807028	BEARING EYELET CENTRE SLEEVE
2	Bearing Spacer	1800032	EYELET BEARING SPACER, T:6.3, FOR 40 MM LINK WIDTH
1	Rock Shox Complete Kit	11.4118.091.806	ROCK SHOX HARDWARE 8 x 20.0

Assembly *Element Forward Shock Hardware*
Dimensions *20x8mm (Shock Pin Width x Hardware Diameter)*

QTY	ITEM	PART NUMBER	DESCRIPTION
1	Fox Complete Kit	803-03-326	FOX Mounting Hardware - 9 Piece AL 8mm x 20/0.787"
1	Rock Shox Complete Kit	11.4118.091.806	ROCK SHOX HARDWARE 8 x 20.0

SUSPENSION SETUP

2025 ELEMENT FOX FLOAT AIR SHOCK

SHOCK DIMENSIONS ALL SIZES = 190 X 45MM
 SHOCK TUNE XS - SM = NO VOLUME SPACERS, CM, RM, CMF
 MD - XL = 0.1 VOLUME SPACER X 1, CM, RF, CMF
 NOTES *COUNT CLICKS FROM CLOSED: 0 CLICKS = CLOSED*

RIDER WEIGHT	PRESSURE	SHOCK SAG	LSR	HSR	LSC	HSC
100lbs 45kg	100psi 6.9bar		10			
110lbs 50kg	110psi 7.6bar		10			
120lbs 55kg	120psi 8.3bar		10 - 9			
130lbs 59kg	130psi 9bar		9			
140lbs 64kg	140psi 9.7bar		9 - 8			
150lbs 68kg	150psi 10.3bar		8			
160lbs 73kg	160psi 11bar		8 - 7			
170lbs 77kg	170psi 11.7bar	All Sizes 12 - 14mm	7	Not Available	Start Open Adjust to pref- erence	Not Available
180lbs 82kg	180psi 12.4bar		7 - 6			
190lbs 86kg	190psi 13.1bar		6			
200lbs 91kg	200psi 13.8bar		6 - 5			
210lbs 95kg	210psi 14.5bar		5			
220lbs 100kg	220psi 15.2bar		5 - 4			
230lbs 105kg	230psi 15.9bar		4			
240lbs 109kg	240psi 16.5bar		4 - 3			
250lbs 114kg	250psi 17.2bar		3			

2025 ELEMENT ROCK SHOX DELUXE AIR SHOCK

SHOCK DIMENSIONS ALL SIZES = 190 X 45MM
 SHOCK TUNE XS - MD = 0L0 PRL 32SN
 LG - XL = 0L1 PRM 32SN
 NOTES *COUNT CLICKS FROM CLOSED: 0 CLICKS = CLOSED*

RIDER WEIGHT	PRESSURE	SHOCK SAG	LSR	HSR	LSC	HSC
100lbs 45kg	130psi 9bar		6 - 5			
110lbs 50kg	140psi 9.7bar		6 - 5			
120lbs 55kg	150psi 10.3bar		5			
130lbs 59kg	160psi 11bar		5 - 4			
140lbs 64kg	170psi 11.7bar		5 - 4			
150lbs 68kg	180psi 12.4bar		4			
160lbs 73kg	190psi 13.1bar		4 - 3			
170lbs 77kg	200psi 13.8bar	All Sizes 12 - 14mm	4 - 3	Not Available	Start Open Adjust to preference	Not Available
180lbs 82kg	210psi 14.5bar		3			
190lbs 86kg	220psi 15.2bar		3 - 2			
200lbs 91kg	230psi 15.9bar		3 - 2			
210lbs 95kg	240psi 16.5bar		2			
220lbs 100kg	250psi 17.2bar		2 - 1			
230lbs 105kg	260psi 17.9bar		2 - 1			
240lbs 109kg	270psi 18.6bar		1			
250lbs 114kg	280psi 19.3bar		1 - Closed			

SUSPENSION SETUP

2025 ELEMENT ROCK SHOX SIDLUXE AIR SHOCK

SHOCK DIMENSIONS ALL SIZES = 190 X 45MM

SHOCK TUNE XS - SM = S1 R81 C27 X8SN
 MD = S1 R85 C30 X8SN
 LG - XL = D1 R85 C33 X8SN

NOTES *COUNT CLICKS FROM CLOSED: 0 CLICKS = CLOSED*

RIDER WEIGHT	PRESSURE	SHOCK SAG	LSR	HBO	LSC	HSC
100lbs 45kg	150psi 10.3bar		7 - 6			
110lbs 50kg	160psi 11bar		7 - 6			
120lbs 55kg	175psi 12bar		7 - 6			
130lbs 59kg	185psi 12.8bar		6 - 5			
140lbs 64kg	195psi 13.4bar		6 - 5			
150lbs 68kg	205psi 14.1bar		6 - 5			
160lbs 73kg	220psi 15.2bar		6 - 5			
170lbs 77kg	230psi 15.9bar	All Sizes 12 - 14mm	5 - 4	Not Available	Start Open Adjust to preference	Not Available
180lbs 82kg	240psi 16.5bar		5 - 4			
190lbs 86kg	250psi 17.2bar		5 - 4			
200lbs 91kg	265psi 18.3bar		3 - 4			
210lbs 95kg	275psi 19bar		3 - 4			
220lbs 100kg	290psi 20bar		3 - 4			
230lbs 105kg	305psi 21bar		2 - 3			
240lbs 109kg	320psi 22bar		2 - 3			
250lbs 114kg	330psi 22.8bar		2 - 3			

CABLE ROUTING HOW-TO

These are instructions for the carbon Element frame only.

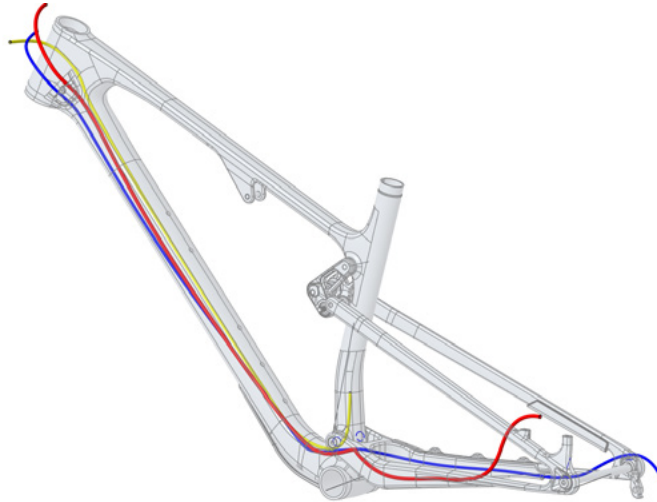

Removing the rear wheel and main pivot bolt will allow you to separate the rear triangle and give better access to direct the housing in the area between the rear and front triangles.

The tube-in-tube channels in the chainstay can sometimes be a tight fit, especially with the curves they sometimes must navigate. Spray soapy water into the opening as a lubricant to help with fitting the housing from one end to the other. Do not use grease or oil; this will leave a mess and attract dirt.

REPLACING/INSTALLING REAR DERAILLEUR CABLE HOUSING

If you are replacing the old housing, remove it and cut a new piece to the same length. If you do not have the old piece, approximate the length required and cut a slightly longer portion.

1. Remove non-drive side head tube port cover.

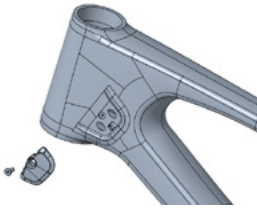

2. Beginning from the rear of the bike, begin feeding the housing into the cable opening on the drive side chain stay. Push the housing forward and simultaneously twist the housing until it comes out at the forward end of the chain stay.

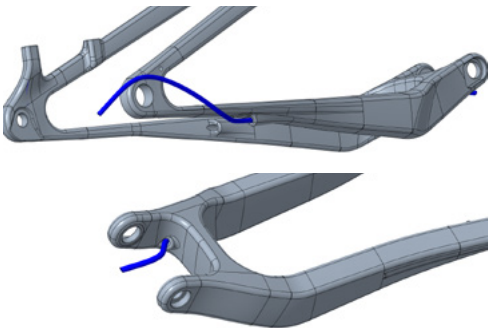

3. Guide the housing into the housing port above the bottom bracket. Make sure you insert the derailleur housing into the drive side port.

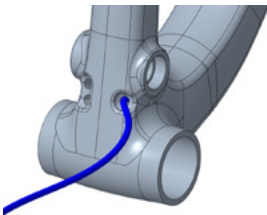

4. Push the cable from the rear until it comes out at the head tube port.

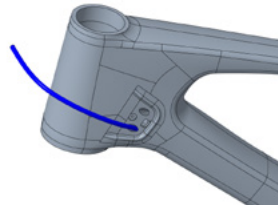

5. Once the housing is fully installed between the shifter and rear derailleur, re-install the headtube port.

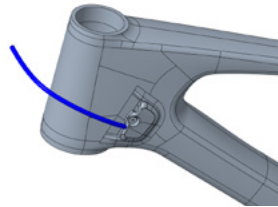

6. Clamp the rear loop out housing to the seatstay using the plastic P clip and M5 screw.

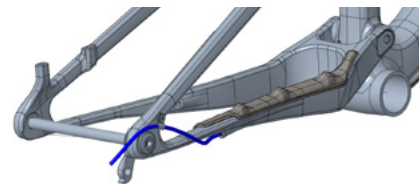

REPLACING/INSTALLING DROPPER POST CABLE HOUSING

If you are replacing the old housing, remove it and cut a new piece to the same length. If you do not have the old piece, approximate the length required and cut a slightly longer portion.

1. Remove drive side head tube port cover.

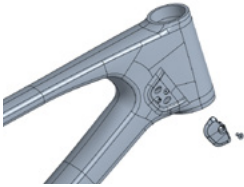

2. Carbon: beginning from the head tube port, begin feeding the housing into the bottom housing opening. Push the housing forward until it comes out at the seat tube.

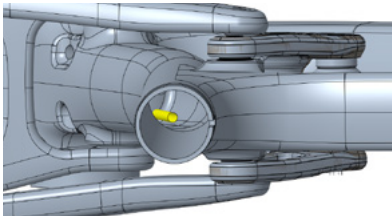
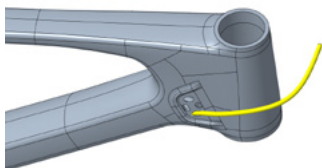

3. Complete the dropper post installation as per the dropper post manufacturer's instructions.

4. Once the seat post is correctly installed, re-install the headtube port.

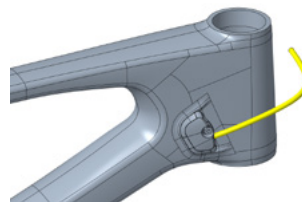

REPLACING/INSTALLING REAR HYDRAULIC BRAKE HOSE

1. Depending on the location of the rear brake hose, remove the drive or non-drive side head tube port cover. If

Regular Routing = Non-Drive side

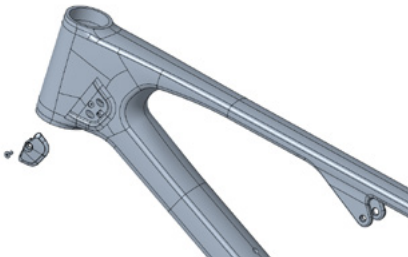

Moto | UK-AUS Routing = Drive side

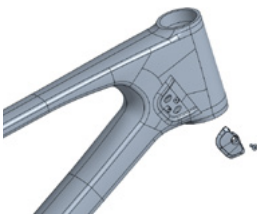

2. For Alloy frames, remove the cover on the inside of the chainstay

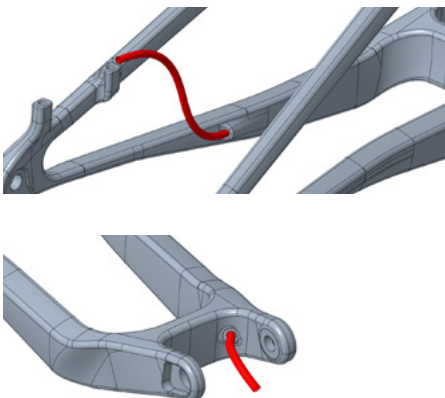

3. Guide the brake hose (red) into the non-drive side housing port above the bottom bracket. For Carbon frames, note the option to route the rear brake hose for regular or Moto | UK-AUS-JPN style. The upper option is for regular routing. The lower option is for Moto routing.

Regular Routing = Upper Tube

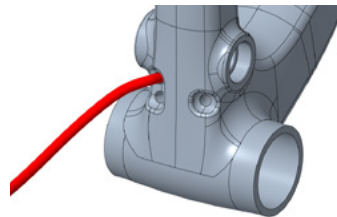

Moto | UK-AUS Routing = Lower Tube

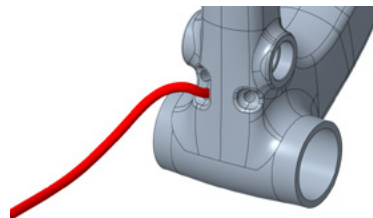

REPLACING/INSTALLING REAR HYDRAULIC BRAKE HOSE

4. Then Push the brake hose from the rear until it comes out at the head tube port.

REGULAR:

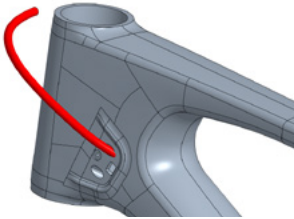

MOTO:

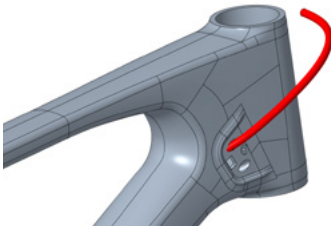

5. Once the brake hose is installed replace the headtube port cover.

REGULAR:

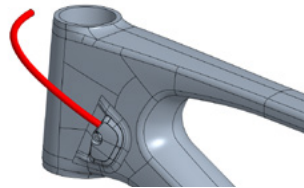

MOTO:

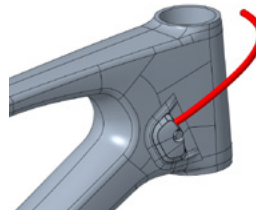

Moto | UK-AUS Routing = Upper Tube

CRITICAL DIMENSIONS



ITEM NUMBER	CATEGORY	ITEM	DIMENSION	PART NUMBER	DESCRIPTION
1	Headset	Carbon Frame Headset	FSA No.57e Orbit 1.5ZS		FSA ZS44/56 Headset Commonly referred to as No.57e or Orbit 1.5ZS See Headset chart for information
		Alloy Frame Headset	FSA No.57e Orbit 1.5ZS		FSA ZS44/56 Headset Commonly referred to as No.57e or Orbit 1.5ZS See Headset chart for information
2	Fork	Fork Travel	130mm		Compatible with 140mm
		Fork Offset	27.5" XS = 37 - 44mm		The XS, frame is equipped with 27.5 wheels, but comes with either a 130mm 27.5 or 120mm 29 fork depending on the fork model.
			29" SM - MD - LG - XL = 42 - 44mm		
		Maximum Axle to Crown Height	27.5" XS = 533mm		29" SM - MD - LG - XL = 552mm
3	Shock	Shock Size	XS - SM - MD - LG - XL = 190 x 45mm		
		Shock Tune	See Description		Refer to Shock Setup chart for tune information
		Forward Shock Hardware	20 x 8mm		Requires custom hardware. See Shock Hardware chart for information
		Rear Shock Hardware	8 x 40mm	1811007	Requires custom bearing eyelet hardware. See Shock Hardware chart for information
		Approved Shock Fitment	See Description		All Fox rear shock models except Float X2 All Rock Shox rear shock models except Vivid Air All DB Inline models Other rear shock manufacturers' models may fit, but will require fitment on frame to check clearances at full extension and compression
4	Seatpost	Seat Tube Inner Diameter	30.9mm		For seatpost sizing
		Seat Tube Outer Diameter	34.9mm		For seat clamp sizing
		Seat Tube Minimum Insertion	100mm XS = 200 SM = 200		
		Seat Tube Machined Ream Depth	MD = 230 LG = 260 XL = 280		
					For seatpost fitment information, refer to the seatpost fitment section in this manual

CRITICAL DIMENSIONS



ITEM NUMBER	CATEGORY	ITEM	DIMENSION	PART NUMBER	DESCRIPTION
5	Crankset	Chainring Size Range	Minimum = 30 Maximum 34T		
		OEM Chainring Size Chain Length	27.5" XS = 32T 116L 29" SM - MD - LG - XL = 32T 118L		
		Chain Guide Kit	See Description	1811008	Canadarm 1.0 + OneUp Upper Guide Complete Kit
		Chain Guide	OneUp Top Guide	IC0686	OneUp kit only
		Bashguard	N/A		
		Bottom Bracket	PressFit BB92		
6	Brake	Chainline Range	52 - 55mm		Compatible with Sram and Shimano 52 - 55mm drivetrain systems
		Maximum Rotor Diameter	203mm		
		Maximum Rotor Thickness	2.3mm		
7	Wheel	Wheel Size	XS = 27.5" SM - MD - LG - XL = 29"		This platform is not MX Mullet compatible
		Maximum Tire Width	2.5" 64mm		
		Hub Spacing	12 x 148mm		
8	Rear Hub	Rear Axle	12 x 1.0 x 173mm	3222000	Diameter 12mm x Thread Pitch 1.0mm x Length 173mm
		Complete Hanger Kit	See Description	1812002	Includes Hanger, nut, and washer. For individual parts see exploded diagram
		UDH Transmission	See Description		Frame is UDH and Transmission compatible

EXPLODED VIEW

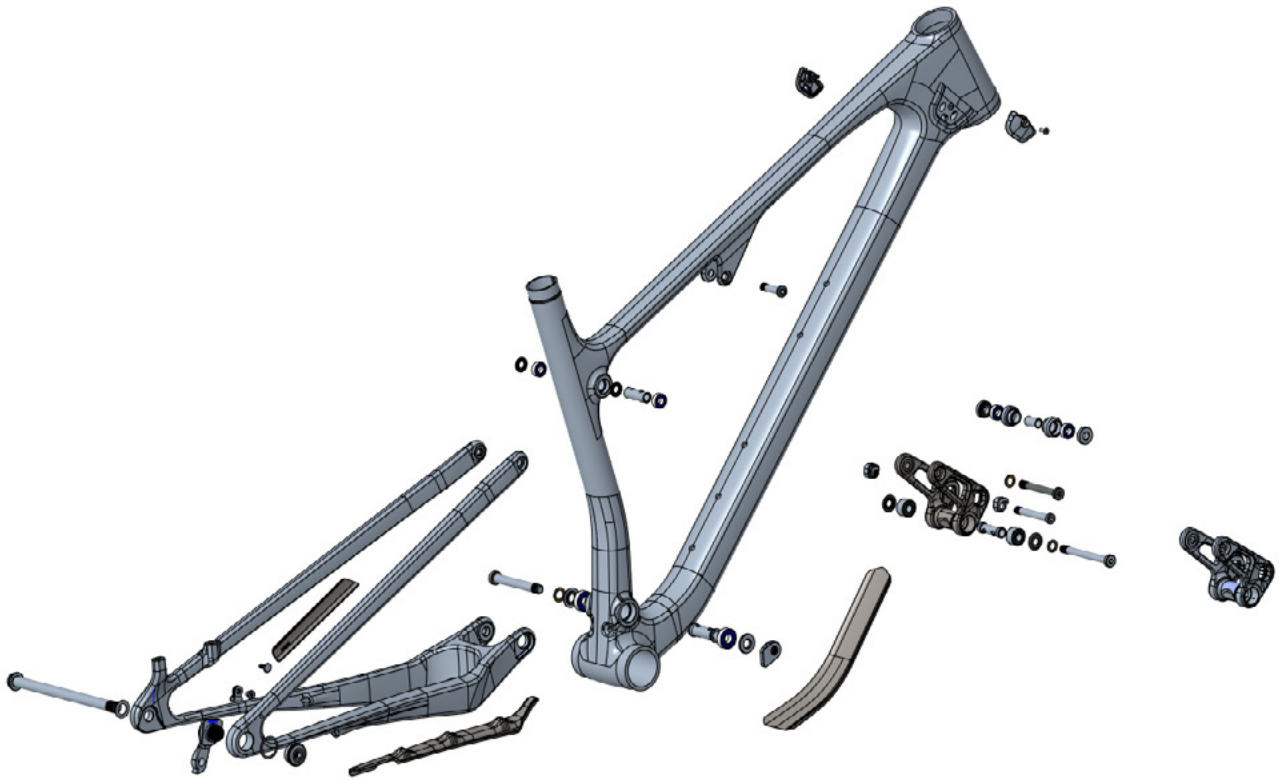

PARTS LIST AND ASSEMBLY INSTRUCTIONS

2025 ELEMENT CARBON						
#	QTY	ITEM	PART NO.	SUPPLIER	REVISION	DESCRIPTION
			1815078	ZCA013		2025 ELEMENT LINK KIT WITH BEARINGS 29" S-XL
18	1	LINK	1095006			MY25 ELEMENT LINK 29", S-XL, 75MM, 6061-T6, HARD BLACK ANODIZED
3	2	BEARING	1805182			ABI 398LLU MAX, 2RS, 8 X 19, 10/11MM,
31	1	SLEEVE	1805047			LOWER LINK SLEEVE, 36 x 8MM ID, NECKED, 6061-T6, HARD BLACK ANO
			1815079	ZCA013		2025 ELEMENT LINK KIT WITH BEARINGS 27.5" XS
19	1	LINK	1095007			MY25 ELEMENT LINK 27.5", XS, 71.5MM, 6061-T6, HARD BLACK ANODIZED
3	2	BEARING	1805182			ABI 398LLU MAX, 2RS, 8 X 19, 10/11MM,
31	1	SLEEVE	1805047			LOWER LINK SLEEVE, 36 x 8MM ID, NECKED, 6061-T6, HARD BLACK ANO
			1812002			2022 HANGER KIT 12 x1.0
14	1	HANGER	1092003	PTW047		MY22 REAR DER. HANGER, M12X1, UDH COMPATIBLE
15	1	HANGER NUT	1801008	PTW047		RMB UDH HANGER NUT, 7075_T6, HARD BLACK ANODIZED
38	1	WASHER	1801009	PTW047		WASHER, 20X24X0.5MM, 304 SS
			1815080	PTW047		2025 ELEMENT CR PIVOT BOLT KIT
5	1	BOLT	1801005			MP BOLT, M10X1.25, L:75, 6MM HEX
36	2	SPACER	1805183			MAIN PIVOT WASHER, 10MM ID X 22MM OD, 6061-T6, HARD BLACK ANODIZED
37	1	WASHER	1800019			WASHERID: 10.2, OD: 15.5, T:1
20	1	MP CHIP	1802013			MAIN PIVOT CHIP, NO KEY
9	1	BOLT	1805167			UPPER LINK BOLT, 61 x 8MM x M1.0, 7075-T6, HARD BLACK ANODIZED
34	2	SPACER	1800039			DO BEARING SPACER, OD:16, ID:8, T:1.75, 6061 ALU
39	2	WASHER	1802011			WASHER ID: 8.2, OD: 13.5, T: 1
8	1	BOLT	1805046			LINK BOLT LOWER, M8 x 1, L: 80mm, 5mm HEX
35	2	SPACER	1805048			LOWER LINK WASHER, 8MM ID, 18.5MM OD, 6061_T6, HARD BLACK ANODIZED
			1815081	ZCA013		2025 ELEMENT CR PIVOT BEARING KIT
2	2	BEARING	1801010			ENDURO 688 LLU MAX 16X8X5
3	2	BEARING	1805182			ABI 398LLU MAX, 2RS, 8 X 19, 10/11MM,
4	2	BEARING	1807042			ENDURO 6900 2RS MAX 22X10X6
30	1	SLEEVE	1802003			TT BEARING SLEEVE. ID: 8, OD: 11.5, L: 32.4
31	1	SLEEVE	1805047			LOWER LINK SLEEVE, 36 x 8MM ID, NECKED, 6061-T6, HARD BLACK ANO
32	1	SLEEVE	1805187			MAIN PIVOT BEARING SLEEVE, OD:15, ID:10, T:39.5
			1812005	PTW047		SHOCK BOLT KIT ELEMENT 2022
6	1	BOLT	1802007			SHOCK BOLT, M8x1.0, L:31.5, 5mm hex
7	1	BOLT	1802008			RIDE 4 BOLT, M8 x 1, OD: 8 mm, L:56, 5 mm Hex
			1811007	ZCA013		SHOCK BEARING EYELET KIT 2021
2	2	BEARING	1801010	PUS098		ENDURO 688 LLU MAX 16X8X5
33	1	SLEEVE	1807028	PTW047		BEARING EYELET CENTRE SLEEVE
10	2	BRG CUP	1800031	PTW047		BEARING EYELET FOR 16X8X5 BRG
11	2	BRG SPACER	1800032	PTW047		EYELET BEARING SPACER, T:6.3, FOR 40 MM LINK WIDTH
			1812007			AXLE KIT BOOST 12X1.0
1	1	AXLE, REAR	3222000	PTW047		REAR AXLE 12X1.0 L:173MM, HARD BLACK ANODIZE
40	1	WASHER	3227006	PTW047		WASHER, 12x19x0.5MM, 304 SS
			1813467	PTW047		NEW HEAD TUBE PANEL KIT (FROM 2023)
16	1	HT PORT COVER	1803012	PTW047		2023 SLAYER CARBON HT PORT COVER, RIGHT
17	1	HT PORT COVER	1803013	PTW047		2023 SLAYER CARBON HT PORT COVER, LEFT
28	2	SCREW, M4X10	1800024-BK	PTW047		C'SUNK SOCKET SCREW, M4x10MM, 10.9 STEEL, BLACK
			1814029	PTW047		RIDE 4 THREADED 10MM CHIP KIT
25	1	RIDE 4 CHIP	1802009			RIDE 4 CHIP, NO THREAD.
26	1	RIDE 4 CHIP	1802010			RIDE 4 CHIP, THREADED, M8 x 1.

SMALL PARTS KITS LIST

		1815082	ZCA013	2025 ELEMENT PROTECTION KIT
22	1 PROTECTOR	1705001		MY25 ELEMENT CHAINSTAY PROTECTOR, TPE, TEXTURED, 50A
23	1 PROTECTOR	1705002		MY25 ELEMENT SEATSTAY PROTECTOR, TPE10A,
24	1 PROTECTOR	3702014		DOWNTUBE PROTECTOR
		1815083	ZCA013	2025 ELEMENT CR SHIFT HOUSING CLIP KIT
12	1 CLIP	1992035		CABLE P CLIP, 5MM HOLE
29	1 SCREW	1804087		LOW-PROFILE HEAD SCREW, HEX, M5 X 0.8, LENGTH 6MM, STAINLESS, ED BLACK
		1815084	ZCA013	2025 ELEMENT REAR TRIANGLE PLUG KIT
21	1 PLUG	1804020		M5_RIVNUT_PLUG, BLACK PLASTIC

SMALL PARTS KITS LIST

#	QTY	ITEM	PART NO.	TORQUE (Nm)	DESCRIPTION	INSTALLATION NOTES
1	1	AXLE, REAR	3222000	10	REAR AXLE 12X1.0 L:173MM, HARD BLACK ANODIZE	GREASE SHAFT AND THREADS
2	4	BEARING	1801010		ENDURO 688 LLU MAX 16X8X5	
3	2	BEARING	1805182		ABI 398LLU MAX, 2RS, 8 X 19, 10/11MM,	
4	2	BEARING	1807042		ENDURO 6900 2RS MAX 22X10X6	
5	1	BOLT	1801005	12	MP BOLT, M10X1.25, L:75, 6MM HEX	GREASE ON SHAFT, BLUE LOCTITE ON THREADS
6	1	BOLT	1802007	10	SHOCK BOLT, M8x1.0, L:31.5, 5mm hex	GREASE ON SHAFT, BLUE LOCTITE ON THREADS
7	1	BOLT	1802008	8	RIDE 4 BOLT, M8 x 1, OD: 8 mm, L:56, 5 mm Hex	GREASE ON SHAFT, BLUE LOCTITE ON THREADS
8	1	BOLT	1805046	8	LINK BOLT LOWER, M8 x 1, L: 80mm, 5mm HEX	GREASE ON SHAFT, BLUE LOCTITE ON THREADS
9	1	BOLT	1805167	8	UPPER LINK BOLT, 61 x 8MM x M1.0, 7075-T6, HARD BLACK ANODIZED	GREASE ON SHAFT, BLUE LOCTITE ON THREADS
10	2	BRG CUP	1800031		BEARING EYELET FOR 16X8X5 BRG	
11	2	BRG SPACER	1800032		EYELET BEARING SPACER, T:6.3, FOR 40 MM LINK WIDTH	
12	1	CLIP	1992035		CABLE P CLIP, 5MM HOLE	
13	1	FT	1065233CBN		MY25 ELEMENT CARBON FRONT TRIANGLE, LARGE	
14	1	HANGER	1092003		MY22 REAR DER. HANGER, M12X1, UDH COMPATIBLE	
15	1	HANGER NUT	1801008	20	RMB UDH HANGER NUT, 7075_T6, HARD BLACK ANODIZED	BLUE LOCTITE ON THREADS
16	1	HT PORT COVER	1803012		2023 SLAYER CARBON HT PORT COVER, RIGHT	
17	1	HT PORT COVER	1803013		2023 SLAYER CARBON HT PORT COVER, LEFT	
18	1	LINK	1095006		MY25 ELEMENT LINK 29", S-XL, 75MM, 6061-T6, HARD BLACK ANODIZED	
19	1	LINK	1095007		MY25 ELEMENT LINK 27.5", XS, 71.5MM, 6061-T6, HARD BLACK ANODIZED	
20	1	MP CHIP	1802013		MAIN PIVOT CHIP, NO KEY	
21	1	PLUG	1804020		M5_RIVNUT_PLUG, BLACK PLASTIC	
22	1	PROTECTOR	1705001		MY25 ELEMENT CHAINSTAY PROTECTOR, TPE, TEXTURED, 50A	
23	1	PROTECTOR	1705002		MY25 ELEMENT SEATSTAY PROTECTOR, TPE10A,	
24	1	PROTECTOR	3702014		DOWNTUBE PROTECTOR	
25	1	RIDE 4 CHIP	1802009		RIDE 4 CHIP, NO THREAD.	
26	1	RIDE 4 CHIP	1802010		RIDE 4 CHIP, THREADED, M8 x 1.	
27	1	RT	1055231CBN		MY25 ELEMENT CARBON REAR TRIANGLE, SIZE S-XL	
28	2	SCREW	1800024-BK	2	C'SUNK SOCKET SCREW, M4x10MM, 10.9 STEEL, BLACK	DRY
29	1	SCREW	1804087	2	LOW-PROFILE HEAD SCREW, HEX, M5 X 0.8, LENGTH 6MM, STAINLESS, ED BLACK	BLUE LOCTITE ON THREADS
30	1	SLEEVE	1802003		TT BEARING SLEEVE. ID: 8, OD: 11.5, L: 32.4	
31	1	SLEEVE	1805047		LOWER LINK SLEEVE, 36 x 8MM ID, NECKED, 6061-T6, HARD BLACK ANO	
32	1	SLEEVE	1805187		MAIN PIVOT BEARING SLEEVE, OD:15, ID:10, T:39.5	
33	1	SLEEVE	1807028		BEARING EYELET CENTRE SLEEVE	
34	2	SPACER	1800039		DO BEARING SPACER, OD:16, ID:8, T:1.75, 6061 ALU	
35	2	SPACER	1805048		LOWER LINK WASHER, 8MM ID, 18.5MM OD, 6061_T6, HARD BLACK ANODIZED	
36	2	SPACER	1805183		MAIN PIVOT WASHER, 10MM ID X 22MM OD, 6061-T6, HARD BLACK ANODIZED	
37	1	WASHER	1800019		WASHERID: 10.2, OD: 15.5, T:1	
38	1	WASHER	1801009		WASHER, 20X24X0.5MM, 304 SS	
39	2	WASHER	1802011		WASHER ID: 8.2, OD: 13.5, T: 1	
40	1	WASHER	3227006		WASHER, 12x19x0.5MM, 304 SS	

WARRANTY INFORMATION

Your bicycle is warranted against defects in materials and manufacturing as per the following table:

CATEGORY	TERM	NOTES
Frame members	5 years	Front triangle + rear triangle, links
Hardware	1 year	Pivots, axles, etc.
Drive wear items	1 year	Pulleys, pinions, transfer chain
Battery	2 years	If stored for 3+ months, charge battery every 3 months. Failure to do so may cause damage.
Components	As per original manufacturer warranty	

All warranty and after-sale service must be handled by the Authorized Rocky Mountain Dealer who sold the complete bicycle or frame. We cover your Rocky Mountain frame from the original date of purchase of your new bicycle against defects in material and workmanship, according to the frame material and the type of use made of the bicycle.

Rocky Mountain's limited warranty also covers bicycles previously used for personal and commercial activity such as rental (including at bike parks), courier services, police, security, etc., against defects in material and workmanship. The limited warranty applies for the remainder of the warranty period from the original date of purchase from Rocky Mountain. In such cases, hardware, bearings, pivots, and bushings are excluded from our warranty policy. The original sales receipt, bicycle registration confirmation or other proof of purchase is required for all claims.

For 2021 bikes and newer models, the original limited warranty is transferable to second-hand owners. For the limited warranty to apply, the registration of the bike must be done online both by the original owner and the second-hand owner. The original invoice will not be required for the second-hand owner.

Please register the bike to transfer the warranty.

Frame material / Type of use

- Carbon fiber: 5 years - Limited*
- Aluminum: 5 years - Limited*
- Please refer to limitations stated below

Other warranty coverage against defects in workmanship and materials

- Coating - paint and decals: 1 year
- Frame hardware, suspension pivots, and bushings: 1 year
- *Links are part of the frame

bikes.com/registration

WARRANTY INFORMATION

NOTE

Warranty is not valid in the following situations:

- Installation and use of components, parts, or accessories not originally intended for or compatible with the bicycle (or frame) as sold.
- Purchasing a Rocky Mountain Bicycle from an unauthorized dealer.
- Purchasing a Rocky Mountain Bicycle or frame off third party internet sites (as eBay), no matter what the listing says.
- Paint fading caused by the effects of ultraviolet light (UV) or outdoor exposure is not covered by this limited warranty.
- Rocky Mountain does not warrant against any damage caused to your bicycle during installation or removal of any protective film products.
- Scratches or chips in the paint caused by dirt, rocks, road debris, rack transport, etc., is not covered by this limited warranty.
- Damage to the Pressfit bottom bracket caused by improper service, materials or parts is not covered by the Rocky Mountain Limited Warranty.

Detail of what is not covered under warranty:

- A. Normal wear and tear on tires, tubes, brakes, gear cables, brake pads, bearings, etc., are not covered. Your authorized Rocky Mountain dealer will inform you of what these normal maintenance items consist of.
- B. Consequential damage or any damage caused by accident, misuse, or abuse.
- C. Improper assembly or lack of proper maintenance, sandblasting, sanding, grinding, wire brushing, filing, welding, brazing, drilling holes, anodizing, repainting, or chrome plating is not covered under our warranty and may void the warranty of the other components.
- D. You take great personal risk and shall forfeit the warranty, as outlined in the Warranty Table, when you ride in extreme terrain as depicted in mountain bike videos (ie. ride «trials» style courses, ride ramps, do stunts, ride on BMX tracks, ride in the city downstairs and embankments, or ride in other similar terrain). It is important to note that bent components, frames, forks, handlebars, seat posts, pedals, cranks, and wheel rims are signs of accidents or abuse.
- E. Labour for part replacement or changeover is not included.
- F. Rocky Mountain retains the right to repair or replace at its discretion any part that is deemed a valid warranty. Please note that Rocky Mountain will do all it can to ensure but cannot guarantee a colour match to the original component.

EXCLUSION AND LIMITATION OF DAMAGES

ROCKY MOUNTAIN'S WARRANTY IS LIMITED TO THE REPAIR OR REPLACEMENT OF THE PRODUCTS AND DOES NOT GRANT ANY WARRANTY EITHER EXPRESSED OR IMPLIED, LEGAL OR CONVENTIONAL AND DISCLAIMS ANY AND ALL IMPLIED WARRANTIES OF MERCHANTABILITY AND FITNESS FOR PARTICULAR PURPOSES AND ROCKY MOUNTAIN SHALL UNDER NO CIRCUMSTANCES BE LIABLE FOR DIRECT OR INDIRECT, SPECIAL, INCIDENTAL OR CONSEQUENTIAL DAMAGES EVEN WHEN ROCKY MOUNTAIN HAS BEEN ADVISED OF SUCH DAMAGES, AND ROCKY MOUNTAIN'S LIABILITY SHALL BE LIMITED TO \$50.00.

INTRODUCTION

L'Element est conçu pour l'efficacité : vous serez inspiré à sprinter dans les montées et surpris par votre rythme dans les descentes. Conçu pour être plus performant et gérer les sentiers techniques mieux que jamais, l'Element trouve un équilibre entre poids, rigidité et confort. Le design amélioré de la suspension Smoothlink SL et les détails du cadre favorisent une conduite précise, faisant de l'Element le vélo parfait pour ceux qui chronomètrent leurs performances, poursuivent un ami ou partent simplement pour une longue journée en selle.

Ce manuel contient des informations importantes sur la sécurité, l'entretien et l'utilisation. Lisez-le attentivement et comprenez-le avant votre première sortie sur votre nouveau vélo Rocky Mountain. Ce document s'applique uniquement à la plateforme spécifique que vous avez choisie et doit être utilisé en complément de votre Manuel du Propriétaire Rocky Mountain, qui est inclus avec votre vélo. Veuillez lire le Manuel du Propriétaire avant votre première sortie. Si vous n'avez pas de copie du Manuel du Propriétaire, vous pouvez l'obtenir auprès de votre revendeur Rocky Mountain autorisé le plus proche.

ÉTIQUETTE

Courtoisie

Toujours être courtois envers les autres utilisateurs des sentiers. Faites preuve de prudence autour des animaux domestiques, comme les chiens et les chevaux. Accordez la priorité à tous les autres utilisateurs des sentiers dans toutes les situations, que ce soit en montée ou en descente.

Sentiers

Ne roulez votre vélo que sur les sentiers et les chemins autorisés pour l'utilisation des vélos. Respectez toutes les lois et réglementations locales. Comme pour tous les utilisateurs des sentiers, veillez à éviter les impacts sur le sentier ou l'environnement. Ne patinez pas sur les sentiers et ne les modifiez pas.

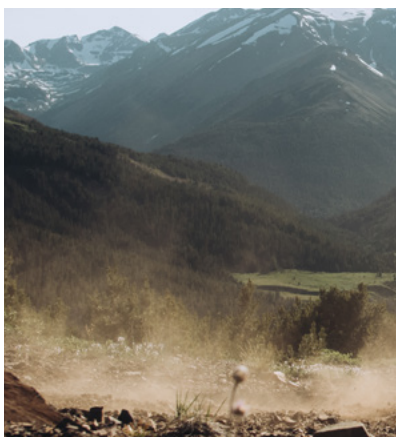

SURVOL DE VOTRE VÉLO



CARACTÉRISTIQUES TECHNIQUES

- La mise à jour du cadre Element présente un tout nouveau design de cadre avec notre nouveau triangle arrière flex stay qui augmente la rigidité et réduit considérablement le poids du cadre.
- Les nouvelles caractéristiques cinématiques Smoothlink SL offre une plus grande sensibilité et à un soutien accru tout au long de la course, dans le but d'augmenter la rigidité et d'améliorer le transfert de puissance.
- La géométrie progressive et les caractéristiques du cadre restent inchangées, garantissant une expérience familière et performante par rapport à la génération précédente très appréciée.
- Proposé dans une large gamme de tailles de cadre et de roues. Le cadre XS est équipé de roues avant et arrière de 27,5 pouces. Les cadres MD-LG-XL sont équipés de roues avant et arrière de 29 ». Cette plateforme n'est pas conçue pour fonctionner avec le réglage mullet, MX.
- Le système de réglage RIDE-4™ permet aux cyclistes d'affiner rapidement leur géométrie à l'aide d'une simple clé Allen.
- Les roulements scellés au niveau de l'œillet d'amortisseur améliorent considérablement la sensibilité aux chocs et sont compatibles avec tous les amortisseurs.
- Notre suspension Smoothlink SL est équipée d'un triangle arrière flex stay qui nous a permis d'éliminer les pivots à roulements des bases. Nous avons ensuite amélioré le pivot du bras de selle avec des roulements à double rangée plus durables, et nous utilisons des roulements communs et faciles à entretenir
- Il y a des protections de roulements partout, y compris des rondelles scellées au niveau du pivot principal, pour aider à prévenir la contamination par les petites particules ou les stations de lavage après la course.
- Le câblage interne entièrement fermé sur nos modèles en carbone et les grands ouvertures sur les modèles en alliage permettent d'installer facilement les câbles et les conduits hydrauliques, de façon standard ou type.
- L'écrou du pivot principal est interchangeable avec celui de l'Instinct pour accepter notre guide-chaîne Canadarm OneUp.
- Le cadre est doté d'un ensemble complet de protections avec nos protections silencieuses en caoutchouc pour les bases, les haubans et le tube diagonal.
- Toutes les tailles de cadre, à l'exception du XS, sont compatibles avec deux bidons à l'intérieur du triangle avant. Le porte-bidon inférieur comporte deux positions de montage afin d'optimiser le positionnement si vous préférez un seul bidon.

GÉOMÉTRIE ET TAILLE

L'Element est un cadre de conception spécifique à la taille qui comporte de nombreux détails qui améliorent l'ajustement et la géométrie pour chaque cycliste.

Taille de la roue

- Le cadre XS est équipé de roues de 27,5 pouces à l'avant et à l'arrière.
- Les cadres SM, MD, LG et XL sont équipés de roues de 29 pouces à l'avant et à l'arrière.
- Cette plate-forme n'est pas conçue pour être compatible avec les réglages mullet/MX.

Ride-4

Le système de réglage RIDE-4™ permet aux cyclistes d'affiner rapidement leur géométrie à l'aide d'une seule clé Allen de 5 mm. Quatre configurations sont possibles grâce à une paire de puces rotatives. Veuillez consulter le tableau de géométrie pour savoir comment chaque position affecte la géométrie. Pour les instructions de réglage, veuillez consulter la section Caractéristiques du cadre.

SOYEZ PRÊTS POUR TOUS LES SENTIERS

Grâce au système d'ajustement RIDE-4™, vous pouvez régler la géométrie avec précision et rapidité au moyen d'une clé hexagonale de 5 mm.

ANGLE PRONONCÉ
DU TUBE DE DIRECTION

SUSPENSION
MOINS
PROGRESSIVE

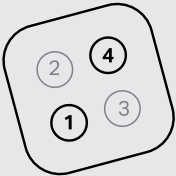

ANGLE ATTENUÉ
DU TUBE DE DIRECTION

SUSPENSION PLUS
PROGRESSIVE



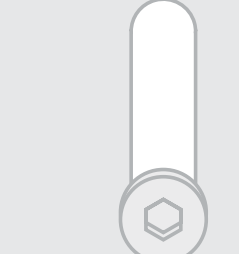





Position 1

 ANGLE ATTENUÉ

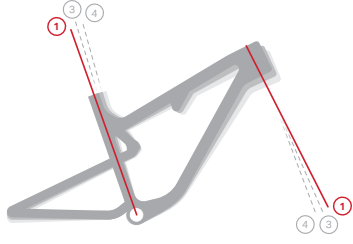
Jeu de pédalier plus bas et suspension progressive améliorant la stabilité à grande vitesse. Position recommandée pour le trail agressif.



Position 3

 NEUTRE

Équilibre entre la performance de la géométrie et de la suspension, adapté à toutes sortes de sentiers.

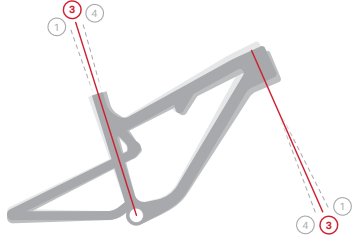

Position 4

 ANGLE PRONONCÉ

Jeu de pédalier plus haut et suspension linéaire offrant un dégagement supérieur au pédalage, un bon support au rapport de suspension initial, et une position sur le vélo adaptée à la montée.



GÉOMÉTRIE ET TAILLE

Taille du cadre

Ce tableau n'est qu'un guide approximatif. Les proportions du cycliste, son style de conduite et ses préférences personnelles sont autant d'éléments qui entrent en ligne de compte dans le choix de la taille du vélo. En général, les vélos plus courts ont tendance à avoir une sensation plus dynamique et plus vive. Les vélos plus longs ont tendance à être plus stables et plus discrets. Rocky Mountain recommande toujours de faire un essai et de faire ajuster le vélo par un professionnel chez un revendeur agréé.

CM	147,5	150	152,5	152,5	155	157,5	160	162,5	165	167,5	170	172,5	175	177,5	180	183	185,5	188	190,5	193	195,5	198
FT-IN	4'7"	4'8"	4'9"	5'0"	5'1"	5'2"	5'3"	5'4"	5'5"	5'6"	5'7"	5'8"	5'9"	5'10"	5'11"	6'	6'1"	6'2"	6'3"	6'4"	6'5"	6'6"
	XS			SM			MD			LG			XL									
XS	█																					
SM				█																		
MD							█															
LG										█												
XL													█									



R: Celeste Pomerantz P: Niklas Wallner L: Norway

TABLEAU DE GÉOMÉTRIE

TAILLE DU CADRE	XS	SM	MD	LG	XL
Taille de roue	27.5			29	
Angle du tube de direction (degrés)	64,7	65	65	65	65
Angle du tube de selle (degrés)	75,7	76	76	76	76
Longueur du tube de selle (mm)	355	380	420	445	480
Longueur du tube horizontal (mm)	542	577	605	632	664
Longueur du tube de direction (mm)	90	105	115	125	135
Longueur de la base arrière (mm)	426	436	436	436	436
Hauteur du boîtier de pédalier (mm)	28	47	47	47	47
Hauteur de surplomb (mm)	769	810	808	806	804
Empattement (mm)	1127	1173	1202	1231	1265
Portée (mm)	397	425	450	475	505
Élévation (mm)	561	606	615	624	633

Angle du tube de direction (degrés)	64,9	65,2	65,2	65,2	65,2
Angle du tube de selle (degrés)	75,9	76,2	76,2	76,2	76,2
Longueur du tube de selle (mm)	355	380	420	445	480
Longueur du tube horizontal (mm)	542	577	604	631	663
Longueur du tube de direction (mm)	90	105	115	125	135
Longueur de la base arrière (mm)	426	435	435	435	435
Hauteur du boîtier de pédalier (mm)	26	43	43	43	43
Hauteur de surplomb (mm)	770	811	809	807	805
Empattement (mm)	1127	1173	1202	1231	1265
Portée (mm)	400	427	452	477	507
Élévation (mm)	563	607	616	625	635

TABLEAU DE GÉOMÉTRIE

TAILLE DU CADRE	XS	SM	MD	LG	XL
Taille de roue	27.5			29	
Angle du tube de direction (degrés)	65,3	65,5	65,5	65,5	65,5
Angle du tube de selle (degrés)	76,1	76,5	76,5	76,5	76,5
Longueur du tube de selle (mm)	355	380	420	445	480
Longueur du tube horizontal (mm)	541	576	603	631	663
Longueur du tube de direction (mm)	90	105	115	125	135
Longueur de la base arrière (mm)	425	435	435	435	435
Hauteur du boîtier de pédalier (mm)	21	40	40	40	40
Hauteur de surplomb (mm)	771	812	810	809	807
Empattement (mm)	1127	1173	1202	1231	1265
Portée (mm)	403	430	455	480	510
Élévation (mm)	565	609	618	627	636
<hr/>					
Angle du tube de direction (degrés)	65,5	65,8	65,8	65,8	65,8
Angle du tube de selle (degrés)	76,5	76,8	76,8	76,8	76,8
Longueur du tube de selle (mm)	355	380	420	445	480
Longueur du tube horizontal (mm)	541	575	603	630	662
Longueur du tube de direction (mm)	90	105	115	125	135
Longueur de la base arrière (mm)	425	435	435	435	435
Hauteur du boîtier de pédalier (mm)	19	36	36	36	36
Hauteur de surplomb (mm)	772	813	811	810	808
Empattement (mm)	1127	1173	1202	1231	1265
Portée (mm)	405	433	458	483	513
Élévation (mm)	566	610	619	628	637

TABLEAU DE GÉOMÉTRIE

Ajustement des tiges de selle télescopiques

Les tiges de selle télescopiques jouent un rôle important dans l'ajustement et le confort des vélos. Vous trouverez ci-dessous les dimensions et mesures critiques qui vous guideront dans la configuration de la tige OEM ainsi que certaines des options possibles si une tige de selle télescopiques du marché secondaire est installée. Le tableau montre l'ajustement de la tige de selle lorsque le débattement de la tige de selle est complètement télescopiques. Cela vous permet de déterminer la position la plus basse ou la plus haute à laquelle votre tige de selle peut être réglée pour obtenir une hauteur correcte en position assise de pédalage. Le tableau vous aidera également à déterminer la taille de la tige de selle à installer si celle du fabricant n'est pas de la taille souhaitée. Veuillez noter que la dimension indiquée va du centre du boîtier de pédalier au sommet de la selle d'origine. La longueur du pédalier peut influencer l'ajustement de la selle et doit également être prise en compte en cas de changement de ce composant.

Comment utiliser le tableau

1. Mesurez la hauteur actuelle de votre selle depuis le centre du pédalier jusqu'au sommet de la selle, en ligne avec la tige de selle.
2. Choisissez le modèle de tige désiré avec son débattement et la grandeur du cadre.
3. Veillez à ce que votre mesure se situe entre les longueurs d'insertion minimale et maximale indiquées dans le tableau.

Exemple : J'ai mesuré 795 mm sur mon vélo actuel. Si je choisis un OneUp V3, avec un débattement de 210 mm, sur un cadre LG Carbon, je peux voir que je peux m'adapter à cette combinaison de débattement et de taille de cadre puisque les mesures minimum et maximum possibles sont de 728 mm à 860 mm.

MODÈLE DE TIGE	SPÉCIFICATION OEM PAR TAILLE DE CADRE	DÉBATTEMENT DE LA TIGE	TAILLE DU CADRE	CARBON					
				XS	SM	MD	LG	XL	
X Fusion Manic	XS - SM	125	Longueur du tube de selle	355	380	420	445	480	
			Insertion minimale	100	100	100	100	100	
			Insertion maximale	200	200	230	260	280	
		MD	125	Hauteur minimale de la selle	599	624	640	665	700
				Hauteur maximale de la selle	671	696	736	761	796
			LG	150	Hauteur minimale de la selle	663	688	698	693
	Hauteur maximale de la selle	725			750	790	815	850	
	XL	170		Hauteur minimale de la selle	707	732	742	737	752
			Hauteur maximale de la selle	739	764	804	829	864	
		200	170	Hauteur minimale de la selle	772	797	807	802	817
	Hauteur maximale de la selle			784	809	849	874	909	
	2025 Fox Transfer *La course est réglable et peut être réduite jusqu'à 25 mm, par incréments de 5 mm.		XS - SM	120	Longueur du tube de selle	574	599	621	646
Insertion minimale		646			671	711	736	771	
MD		150		Insertion maximale	639	664	674	677	712
			Hauteur minimale de la selle	711	736	776	801	836	
		LG	180	Hauteur maximale de la selle	704	729	739	734	749
				Hauteur minimale de la selle	776	801	841	866	901
XL		210	Hauteur maximale de la selle	769	794	804	799	814	
	Hauteur minimale de la selle		841	866	906	931	966		

GÉOMÉTRIE ET TAILLE

MODÈLE DE TIGE	SPÉCIFICATION OEM PAR TAILLE DE CADRE	DÉBATTEMENT DE LA TIGE	TAILLE DU CADRE	CARBON				
				XS	SM	MD	LG	XL
Reverb AXS *L'insertion minimale d'un poteau est de 80 mm, mais le cadre nécessite 100 mm.	XS - SM	125	Longueur du tube de selle	587	612	652	677	712
		125	Insertion minimale	687	712	752	777	812
	MD	150	Insertion maximale	637	662	677	702	737
		150	Hauteur minimale de la selle	737	762	802	827	862
	LG - XL	175	Hauteur maximale de la selle	687	712	722	727	762
		175	Hauteur maximale de la selle	787	812	852	877	912
OneUp V3 Dropper *La course est réglable et peut être réduite jusqu'à 20 mm, par incréments de 10 mm.	XS - SM	120	Longueur du tube de selle	560	585	625	650	685
		120	Insertion minimale	645	670	710	735	770
	MD	150	Insertion maximale	620	645	655	675	710
		150	Hauteur minimale de la selle	705	730	770	795	830
	LG	180	Hauteur maximale de la selle	680	705	715	710	735
		180	Hauteur minimale de la selle	750	775	815	840	875
	XL	210	Hauteur maximale de la selle	740	765	775	770	785
		210	Hauteur minimale de la selle	795	820	860	885	920
		240	Hauteur maximale de la selle	810	835	845	840	855
		240	Hauteur minimale de la selle	850	875	915	940	975
Revive 3 Dropper *La course est réglable et peut être réduite jusqu'à 30 mm, en fonction de l'option de course, par incréments de 5 mm.		125	Longueur du tube de selle	581	606	627	652	687
		125	Insertion minimale	680	705	745	770	805
		160	Insertion maximale	651	676	686	687	722
		160	Hauteur minimale de la selle	730	755	795	820	855
		185	Hauteur maximale de la selle	701	726	736	731	747
		185	Hauteur minimale de la selle	780	805	845	870	905
		213	Hauteur maximale de la selle	766	791	801	796	811
		213	Hauteur minimale de la selle	815	840	880	905	940

SPÉCIFICATIONS ET DIMENSIONS

ZS44|56 à cuvettes semi intégré

Tous les cadres sont équipés de ZS44|56 de jeux de direction ZS44|56 semi intégré

Le cadre Element carbone utilise des cuvettes de jeu de direction enfoncé. Des outils spéciaux sont nécessaires pour retirer et installer les cuvettes dans le cadre. Les jeux de direction pour les cadres en carbone sont fabriqués par FSA et sont souvent identifiés comme le modèle No.57e ou Orbit 1.5zs. Ils utilisent des pièces d'assemblage FSA standard, telles que les roulements et les bagues, afin de garantir que le remplacement des pièces d'usure est un processus sans douleur.

Assemblage Jeu de direction Element Carbone et Alliage
Notes L'Element utilise une variante du jeu de direction FSA No.57e / Orbit 1.5ZS, équipée d'un roulement en acier inoxydable et d'un capuchon supérieur de 5,3 mm.

QTÉ	ITEM	NUMÉRO DE PIÈCE	DESCRIPTION
1	Jeu de direction	121-0501	FSA Part Number No.57E - Orbit 1.5ZS Headset with standard bearings and 8mm top cap
1	Jeu de direction	H018200000E401	FSA Part Number No.57E - Orbit 1.5ZS Headset with stainless bearings and 5.3mm top cap
2	Tube de direction supérieur	N/A	ZS44 Standard
N/A	Tube de direction inférieur	N/A	ZS56 Standard
1	Joint torique en caoutchouc	160-7042	FSA Top Cap Inner Rubber O-Ring
1	Capuchon supérieur	161-4430	FSA 5.3mm Top Cap inc. rubber seal
1	Split Race	160-7626	FSA 1 1/8" Headset Compression Ring
1	Roulement	160-6465	FSA Stainless ACB 1 1/8" 36°x45° Bearing
1	Roulement	160-67400E	FSA Stainless ACB 1.5" 36°x45° Bearing
1	Couronne de direction	160-5536	FSA 1.5" Crown Race

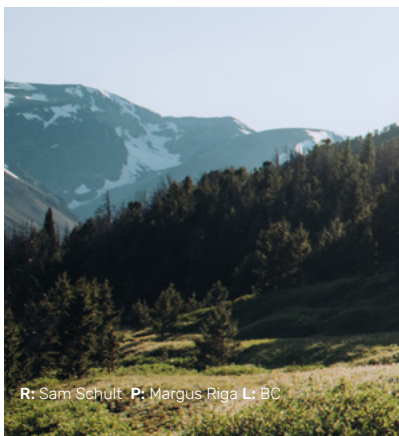

R: Sam Schult. P: Margus Riga L: BC

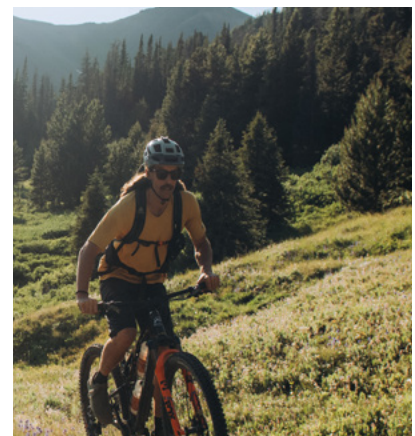
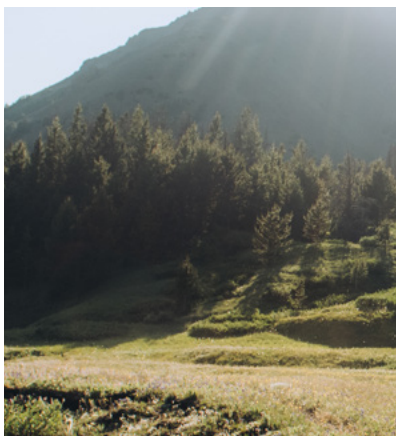

PATTE DE DÉRAILLEUR UDH

Votre nouveau cadre est compatible avec les pattes de dérailleur UDH de Sram. Il n'y a pas d'instructions particulières liées au cadre qui soient nécessaires pour l'installation d'une patte de dérailleur UDH. Pour une installation correcte de la patte UDH de Sram, veuillez consulter les instructions de Sram fournies avec la patte.

ŒILLET DE ROULEMENT D'AMORTISSEUR ET QUINCAILLERIE

Votre cadre est équipé de roulements à cartouche dans les œillets arrière, ce qui permet d'améliorer le comportement sur les petites bosses. Ces roulements sont portés par des coupelles qui s'insèrent très fermement dans l'arbre de l'amortisseur. Si vous envoyez votre amortisseur au centre de service pour une maintenance, nous vous recommandons vivement de retirer ces composants, car les centres de service de suspension ne peuvent pas garantir leur retour.

La quincaillerie avant de l'amortisseur contient des pièces standard fournies par le fabricant de l'amortisseur. Le tableau ci-dessous contient des informations techniques sur l'ensemble des pièces de l'amortisseur, des schémas de référence et des instructions pour le démontage du système d'œillets de roulement.

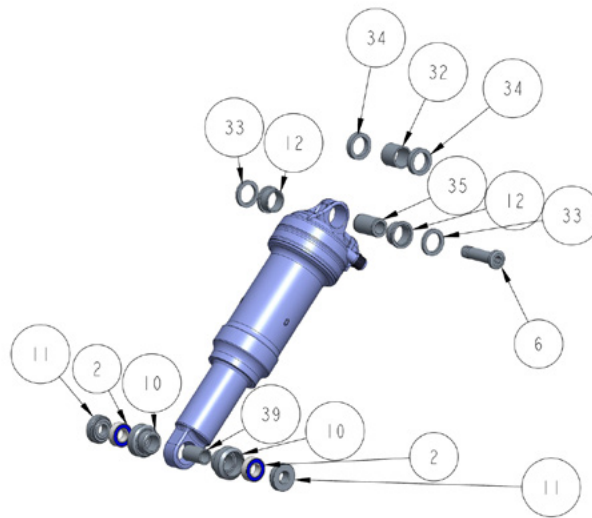

Assemblage L'Element quincaillerie avant de l'amortisseur

Dimensions 20x8mm (largeur de l'axe d'amortisseur x diamètre de la quincaillerie)

QTÉ	ITEM	NUMÉRO DE PIÈCE	DESCRIPTION
1	Fox Complete Kit	803-03-326	FOX Mounting Hardware - 9 Piece AL 8mm x 20/0.787"
1	Rock Shox Complete Kit	11.4118.091.806	ROCK SHOX HARDWARE 8 x 20.0

Conseil de pro : Le kit complet Fox est compatible avec les œillets d'amortisseurs Rock Shox. Retirez la bague en téflon de l'œillet Rock Shox avant d'installer le kit Fox.

ŒILLET DE ROULEMENTS D'AMORTISSEUR ET QUINCAILLERIE

Retrait des œillets

Voici comment retirer le système :

- Utilisez la trousse d'outils pour œillets à roulements de Rocky Mountain (pièce 1810031).
- Insérez la goupille d'un côté de l'œillet.
- Fixez ensuite l'un des outils d'extraction à la cuvette où est insérée la goupille.
- Vissez la vis M8 jusqu'à ce qu'elle soit bien appuyée sur la goupille.
- Fixez l'autre outil d'extraction sur l'autre cuvette.
- Vissez la vis M8 au maximum, jusqu'à ce qu'elle pousse sur la goupille de l'autre côté.
- Continuez à visser jusqu'à ce que l'une des cuvettes soit entièrement extraite.
- Insérez ensuite le poinçon dans l'œillet en l'appuyant solidement sur la cuvette qui est toujours dans l'œillet.
- Avec un marteau, frappez doucement mais fermement sur le poinçon jusqu'à ce que la cuvette soit entièrement extraite de l'œillet.

Si vous n'avez pas la trousse d'outils Rocky Mountain, utilisez un extracteur de roulement intérieur à trou borgne :

- Avec l'extracteur (embout de 8 mm), retirez les deux roulements. Insérez la goupille d'un côté de l'œillet.
- Retirez la douille centrale.
- Avec l'extracteur de palier (embout de 10 mm), retirez les cuvettes vides.

N.B. : Le diamètre intérieur des cuvettes est de 11 mm, et donc trop petit pour l'embout de 12 mm. NE LE FORCEZ PAS. Utilisez plutôt l'embout de 10 mm.

Installez de nouvelles cuvettes avec une presse à palier ou un étau à mâchoires souples en veillant à appuyer sur le bord extérieur des cuvettes. N'oubliez pas la douille-entretoise entre les cuvettes.

CONFIGURATION DE LA SUSPENSION

Avant de modifier les réglages de votre amortisseur, il est important de vous informer sur les différents ajustements possibles.

Ajustement du Ressort

Selon le modèle de l'amortisseur, vous devrez peut-être ajuster la force du ressort à ressort ou la pression d'air pour atteindre l'affaissement recommandé pour l'Instinct. Consultez le tableau des ressorts ci-dessous pour des recommandations sur les forces de ressort et les pressions d'air.

Rebond

L'ajustement du rebond contrôle la rapidité avec laquelle votre suspension revient à son extension complète après avoir rencontré un obstacle. Un contrôle du rebond trop élevé rendra la fourche ou l'amortisseur trop lent à se rétablir, provoquant un enfoncement excessif lors des chocs répétés, ce qui sera inconfortable. À l'inverse, un réglage trop faible peut entraîner un retour trop rapide de la suspension, ce qui peut provoquer une perte de traction et de contrôle.

- Le rebond à vitesse basse (LSR) se réfère à la vitesse de la fourche ou de l'amortisseur à faible vitesse, et non à la vitesse sur le terrain. Cet ajustement influence le taux de rebond dans la première partie de la course de l'amortisseur. Pour simplifier, on peut considérer que cela concerne une course de 0 % à 40 % de la plage de déplacement.
- Le rebond à vitesse élevée (HSR) se réfère à la vitesse de la fourche ou de l'amortisseur à haute vitesse, et non à la vitesse sur le terrain. Cet ajustement influence le taux de rebond dans la seconde partie de la course de l'amortisseur. Pour simplifier, on peut considérer que cela concerne une course de 40 % à 100 % de la plage de déplacement.

Compression

L'ajustement de la compression contrôle la rapidité avec laquelle votre suspension s'enfonce lors d'un choc. Un contrôle de compression trop élevé rendra la fourche ou l'amortisseur trop lent à réagir, ce qui fera reposer l'absorption de l'impact sur le pneu et votre corps. À l'inverse, un réglage trop faible fera que la fourche ou l'amortisseur s'enfoncera trop rapidement, donnant au vélo une sensation de lourdeur et de manque de réactivité.

La compression à vitesse basse (LSC) se réfère à la vitesse de la fourche ou de l'amortisseur à faible vitesse, et non à la vitesse sur le terrain. Elle contrôle les déplacements de poids du cycliste, le pompage sur le terrain, les «G-outs» et autres déplacement lent. Un réglage LSC trop élevé entraînera une sensation de conduite plus dure, tandis qu'un réglage trop faible donnera une sensation trop molle et peu réactive. Le LSC est efficace sur l'ensemble de la plage de déplacement.

La compression à vitesse élevée (HSC) se réfère à la vitesse de la fourche ou de l'amortisseur à haute vitesse, et non à la vitesse sur le terrain. Elle contrôle la capacité d'absorption des gros impacts, tels que les pierres à angles vifs et les enfoncements. Un réglage HSC trop élevé entraînera une sensation de conduite plus dure lorsque vous roulez sur des sentiers rapides et accidentés avec de gros obstacles. À l'inverse, un réglage trop faible ne fournira pas assez de soutien lors de l'impact avec ces gros obstacles, ce qui pourrait entraîner une utilisation complète de votre course de suspension.

Compression de fin de course

La compression de fin de course ou Hydraulic Bottom Out (HBO) désigne la résistance à l'enfoncement que certains amortisseurs peuvent offrir, en combinaison avec un ajusteur externe. Cet ajustement affecte les 20 % derniers de la course de l'amortisseur et est utilisé pour gérer les gros impacts, lorsque la suspension risque de s'enfoncer complètement.

CONFIGURATION DE LA SUSPENSION

Veuillez consulter les tableaux ci-dessous pour toutes les configurations d'amortisseurs OEM pour l'Instinct. En raison du grand nombre d'amortisseurs compatibles avec l'Instinct, nous ne pouvons pas fournir de guides de configuration pour les modèles en dehors des spécifications OEM.

Trucs et astuces pour la suspension

Lorsque vous réglez votre suspension, notez vos réglages afin de pouvoir vous y référer. Mieux encore, utilisez une feuille de calcul en ligne sur votre téléphone !

Le démontage de l'amortisseur sur l'Element avec sa suspension Smoothlink SL est facile mais peut nécessiter quelques conseils et astuces. La principale différence avec notre triangle arrière Smoothlink SL et son design monobloc est que les bases sont conçus pour être statiques et fournir 0 force de ressort à 25% d'affaissement. Lorsque vous retirez l'amortisseur, le triangle arrière voudra revenir à sa position naturelle de repos. La réinstallation de l'amortisseur nécessite une légère flexion pour que tous les derniers boulons, que ce soit au niveau du Pivot du tube de selle ou de la fixation de l'amortisseur, soient alignés.

Voici un guide de démontage étape par étape. Passez au petit pignon de la cassette et verrouillez la cage du dérailleur en l'ouvrant si possible.

1. Placer l'amortisseur dans le lien
 - a. Les entretoises de l'œillet de roulement de chaque côté vont tomber, veillez donc à placer une main sous l'œillet de roulement pour les maintenir en place. pour les maintenir en place.
2. Insérer le boulon de l'amortisseur arrière.
 - a. Si nécessaire, vous pouvez retirer les puces Ride4 des deux côtés du lien de suspension pour que le boulon s'aligne d'abord sur l'œillet du roulement. Une fois que le boulon est à moitié inséré dans l'œillet du roulement, l'alignement de la puce Ride4 sera beaucoup plus facile.
3. Installer le boulon d'amortisseur avant.
 - a. Cette étape nécessite une légère précontrainte du triangle arrière jusqu'à ce que l'œillet de l'amortisseur avant soit aligné avec le trou de montage de l'amortisseur.
4. Une fois les deux boulons d'amortisseurs installés et partiellement filetés, ajoutez un peu de précharge au triangle arrière pour vous assurer que tout le matériel est bien en place et serrez les deux boulons.
5. Serrer tous les éléments de fixation selon les spécifications. Veuillez consulter notre vue explosée pour plus de détails.

Assemblée *Œillet de roulement d'amortisseur arrière Element*

Dimensions *40x8mm (largeur x diamètre de la quincaillerie)*

QTÉ	PIÈCE	NUMÉRO DE PIÈCE	DESCRIPTION
1	Kit complet RMB	1811007	8 x 40mm Kit d'œillets de palier d'amortisseur
2	Ensemble de cuvettes de jeu de direction	1801010	ENDURO 688 LLU MAX 16X8X5
2	Joint torique en caoutchouc	1800031	ŒILLET DE ROULEMENT POUR 16X8X5 BRG
1	Capuchon	1807028	BEARING EYELET CENTRE SLEEVE
2	Joint d'étanchéité en caoutchouc	1800032	ENTRETOISE DE ROULEMENT D'ŒILLET, T:6.3, POUR LARGEUR DE MAILLON DE 40 MM
1	Rock Shox Complete Kit	11.4118.091.806	ROCK SHOX HARDWARE 8 x 20.0

Assemblée *Quincaillerie de l'amortisseur avant de l'Element*

Dimensions *20x8mm (Largeur de la broche de shock x Diamètre de la quincaillerie)*

QTÉ	PIÈCE	NUMÉRO DE PIÈCE	DESCRIPTION
1	Kit complet Fox	803-03-326	Matériel de montage FOX - 9 Piece AL 8mm x 20/0.787"
1	Kit complet Rock Shox	11.4118.091.806	ROCK SHOX HARDWARE 8 x 20.0

CONFIGURATION DE LA SUSPENSION

ELEMENT 2025 AMORTISSEUR FOX FLOAT AIR

DIMENSIONS DE
L'AMORTISSEUR

Toutes les tailles = 190 X 45MM

RÉGLAGE DE
L'AMORTISSEUR

XS - SM = NO VOLUME SPACERS, CM, RM, CMF
MD - XL = 0.1 VOLUME SPACER X 1, CM, RF, CMF

NOTES

COMPTER LES CLICS À PARTIR DE FERMÉ : 0 CLICS = FERMÉ

POIDS DE L'UTILISATEUR	PRESSION	SHOCK SAG	LSR	HSR	LSC	HSC
100lbs 45kg	100psi 6.9bar		10			
110lbs 50kg	110psi 7.6bar		10			
120lbs 55kg	120psi 8.3bar		10 - 9			
130lbs 59kg	130psi 9bar		9			
140lbs 64kg	140psi 9.7bar		9 - 8			
150lbs 68kg	150psi 10.3bar		8			
160lbs 73kg	160psi 11bar		8 - 7			
170lbs 77kg	170psi 11.7bar	Toutes les tailles 12 - 14mm	7	Non disponible	Commencer en position ouverte Ajuster selon la préférence	Non disponible
180lbs 82kg	180psi 12.4bar		7 - 6			
190lbs 86kg	190psi 13.1bar		6			
200lbs 91kg	200psi 13.8bar		6 - 5			
210lbs 95kg	210psi 14.5bar		5			
220lbs 100kg	220psi 15.2bar		5 - 4			
230lbs 105kg	230psi 15.9bar		4			
240lbs 109kg	240psi 16.5bar		4 - 3			
250lbs 114kg	250psi 17.2bar		3			

2025 ELEMENT ROCK SHOX DELUXE AIR SHOCK

DIMENSIONS DE
L'AMORTISSEUR

Toutes les tailles = 190 X 45MM

RÉGLAGE DE
L'AMORTISSEUR

XS - MD = 0L0 PRL 32SN
LG - XL = 0L1 PRM 32SN

NOTES

COMPTER LES CLICS À PARTIR DE FERMÉ : 0 CLICS = FERMÉ

POIDS DE L'UTILISATEUR	PRESSION	SHOCK SAG	LSR	HSR	LSC	HSC
100lbs 45kg	130psi 9bar		6 - 5			
110lbs 50kg	140psi 9.7bar		6 - 5			
120lbs 55kg	150psi 10.3bar		5			
130lbs 59kg	160psi 11bar		5 - 4			
140lbs 64kg	170psi 11.7bar		5 - 4			
150lbs 68kg	180psi 12.4bar		4			
160lbs 73kg	190psi 13.1bar		4 - 3			
170lbs 77kg	200psi 13.8bar	Toutes les tailles 12 - 14mm	4 - 3	Non disponible	Commencer en position ouverte Ajuster selon la préférence	Non disponible
180lbs 82kg	210psi 14.5bar		3			
190lbs 86kg	220psi 15.2bar		3 - 2			
200lbs 91kg	230psi 15.9bar		3 - 2			
210lbs 95kg	240psi 16.5bar		2			
220lbs 100kg	250psi 17.2bar		2 - 1			
230lbs 105kg	260psi 17.9bar		2 - 1			
240lbs 109kg	270psi 18.6bar		1			
250lbs 114kg	280psi 19.3bar		1 - Fermé			

CONFIGURATION DE LA SUSPENSION

2025 ELEMENT ROCK SHOX SIDLUXE AIR SHOCK

DIMENSIONS DE
L'AMORTISSEUR

Toutes les tailles = 190 X 45MM

RÉGLAGE DE
L'AMORTISSEUR

XS - SM = S1 R81 C27 X8SN
MD = S1 R85 C30 X8SN
LG - XL = D1 R85 C33 X8SN

NOTES

COMPTER LES CLICS À PARTIR DE FERMÉ : 0 CLICS = FERMÉ

POIDS DE L'UTILISATEUR	PRESSION	SHOCK SAG	LSR	HBO	LSC	HSC
100lbs 45kg	150psi 10.3bar		7 - 6			
110lbs 50kg	160psi 11bar		7 - 6			
120lbs 55kg	175psi 12bar		7 - 6			
130lbs 59kg	185psi 12.8bar		6 - 5			
140lbs 64kg	195psi 13.4bar		6 - 5			
150lbs 68kg	205psi 14.1bar		6 - 5			
160lbs 73kg	220psi 15.2bar		6 - 5			
170lbs 77kg	230psi 15.9bar	Toutes les tailles	5 - 4	Non disponible	Commencer en position ouverte Ajuster selon la préférence	Non disponible
180lbs 82kg	240psi 16.5bar	12 - 14mm	5 - 4			
190lbs 86kg	250psi 17.2bar		5 - 4			
200lbs 91kg	265psi 18.3bar		3 - 4			
210lbs 95kg	275psi 19bar		3 - 4			
220lbs 100kg	290psi 20bar		3 - 4			
230lbs 105kg	305psi 21bar		2 - 3			
240lbs 109kg	320psi 22bar		2 - 3			
250lbs 114kg	330psi 22.8bar		2 - 3			

PASSAGE DES CÂBLES

Ces instructions ne concernent que le cadre Element en carbone.

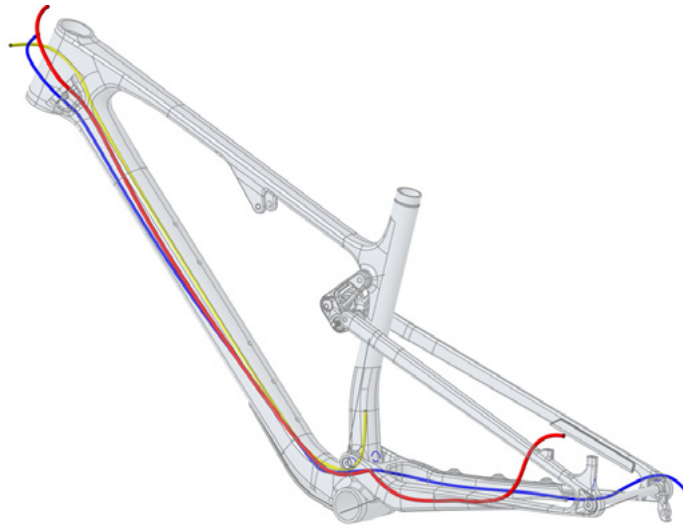

Le démontage de la roue arrière et du boulon de pivot principal vous permettra de séparer le triangle arrière et d'accéder plus facilement les entrées situées entre les triangles arrière et avant.

Les canaux tube-en-tube de la base peuvent parfois être serrés, en particulier dans les courbes qu'ils doivent parfois emprunter. Vaporisez de l'eau savonneuse dans l'ouverture comme lubrifiant pour faciliter le passage de la gaine ou du conduit hydraulique d'un bout à l'autre. N'utilisez pas de graisse ou d'huile ; cela laisserait des traces et attirerait la saleté.

REPLACEMENT OU INSTALLATION DE LA GAINE DU DÉRAILLEUR ARRIÈRE

Si vous remplacez l'ancienne gaine, enlevez-la et coupez une nouvelle pièce de la même longueur. Si vous n'avez pas l'ancienne pièce, évaluez approximativement la longueur requise et coupez une partie légèrement plus longue.

- 1.** Retirez le couvercle de port d'entrée du tube de direction du côté opposé à la transmission.

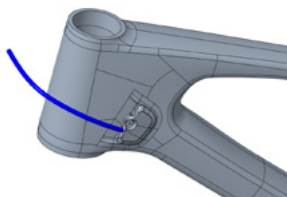

- 2.** En partant de l'arrière du vélo, introduisez la gaine dans le port d'entrée de la base du côté de la transmission. Poussez le câble vers l'avant tout en faisant tourner jusqu'à ce qu'il ressorte à l'autre extrémité de la base.

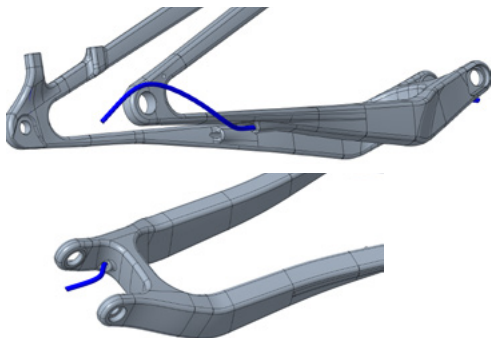

- 3.** Introduisez la gaine dans le port au-dessus du jeu de pédalier. Le câble du dérailleur doit passer dans le port côté transmission.

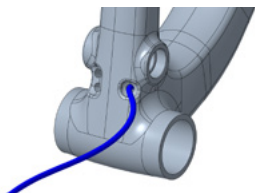

- 4.** Poussez sur le câble à partir de l'arrière jusqu'à ce qu'il ressorte du port du tube de direction.

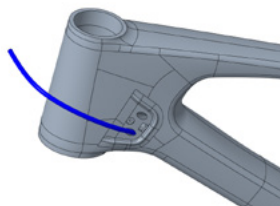

- 5.** Une fois que la gaine est complètement installée entre la manette et le dérailleur arrière, réinstallez le protecteur de port du tube de direction.

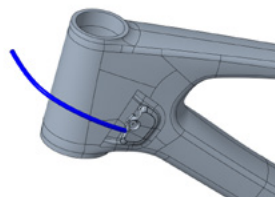

- 6.** Fixez la gaine sur le hauban à l'aide du clip en plastique et de la vis M5.

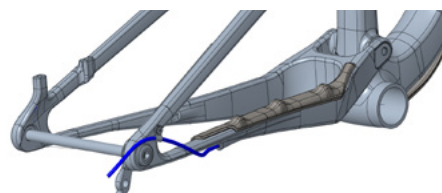

REPLACEMENT OU INSTALLATION DU CÂBLE DE LA TIGE DE SELLE TÉLESCOPIQUE

Si vous remplacez l'ancienne gaine, enlevez-le et coupez une nouvelle pièce de la même longueur. Si vous n'avez pas l'ancienne pièce, évaluez approximativement la longueur requise et coupez une partie légèrement plus longue.

- 1.** Enlevez le couvercle de port d'entrée du tube de direction côté entraînement.

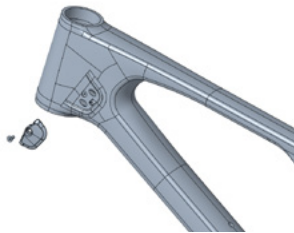

- 2.** Carbone : à partir de l'entrée du tube de direction, introduisez la gaine dans l'ouverture inférieure. Poussez la gaine vers l'arrière jusqu'à ce qu'elle ressorte au niveau du tube de selle.

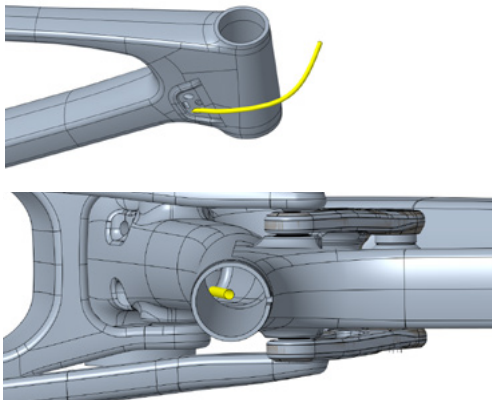

- 3.** Complétez l'installation de la tige de selle en suivant les instructions du fabricant.

- 4.** Une fois la tige de selle correctement installée, réinstallez le couvercle du tube de direction.

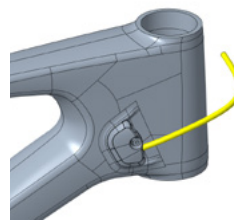

REPLACEMENT OU INSTALLATION DU CÂBLE DE FREIN HYDRAULIQUE ARRIÈRE

1. En fonction de l'emplacement du conduit du frein de frein arrière, retirer le couvercle du port du tube de direction côté coté transmission ou côté opposé à la transmission

Câblage régulier = opposé a la transmission

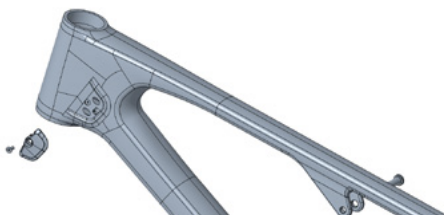

Passage MOTO | UK-AUS = coté transmission

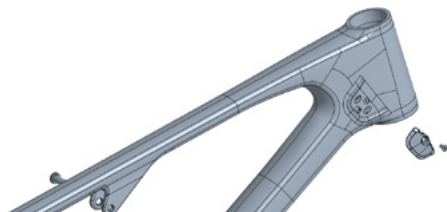

2. Pour les cadres en alliage, retirez le couvercle situé à l'intérieur de la base.

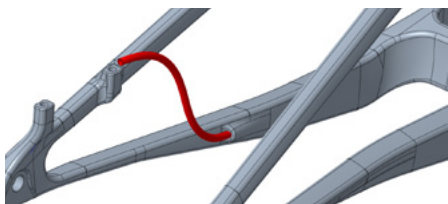

3. Guidez la conduite de frein (rouge) dans l'ouverture côté opposé à l'entraînement, au-dessus du boîtier de pédalier. Pour les cadres en carbone, notez l'option d'acheminement du conduit de frein arrière pour le style régulier ou Moto | UK-AUS-JPN. L'option supérieure correspond à un acheminement régulier. L'option inférieure correspond à l'acheminement Moto.

Câblage régulier = ouverture supérieur

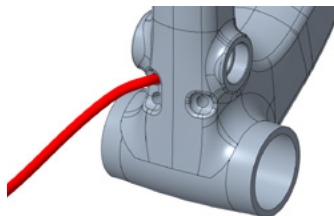

Câblage Moto = ouverture inférieur

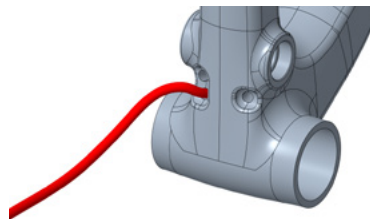

REPLACEMENT OU INSTALLATION DU CÂBLE DE FREIN HYDRAULIQUE ARRIÈRE

4. Pousser ensuite la conduite de frein depuis l'arrière jusqu'à ce qu'elle sorte au niveau de l'ouverture du tube de direction.

RÉGULIER:

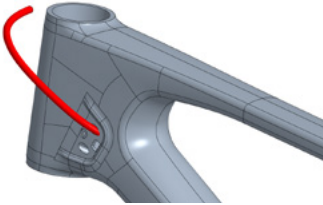

MOTO:

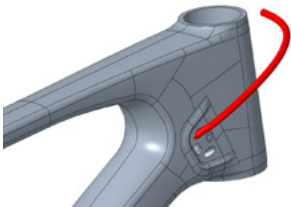

5. Une fois la conduite de frein installé, remplacez le couvercle du port d'entrée du tube de direction.

RÉGULIER:

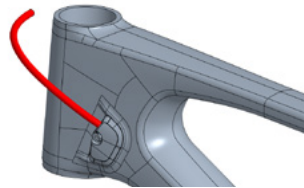

MOTO:

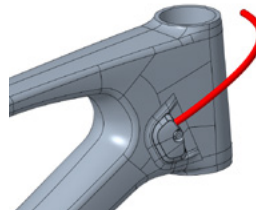

GUIDE DES DIMENSIONS



ITEM NUMBER	CATEGORY	ITEM	DIMENSION	PART NUMBER	DESCRIPTION
1	Headset	Carbon Frame Headset	FSA No.57e Orbit 1.5ZS		FSA ZS44/56 Headset Commonly referred to as No.57e or Orbit 1.5ZS See Headset chart for information
		Alloy Frame Headset	FSA No.57e Orbit 1.5ZS		FSA ZS44/56 Headset Commonly referred to as No.57e or Orbit 1.5ZS See Headset chart for information
2	Fork	Fork Travel	130mm		Compatible with 140mm
		Fork Offset	27.5" XS = 37 - 44mm		The XS, frame is equipped with 27.5 wheels, but comes with either a 130mm 27.5 or 120mm 29 fork depending on the fork model.
		Maximum Axle to Crown Height	29" SM - MD - LG - XL = 42 - 44mm		
			27.5" XS = 533mm		
3	Shock	Shock Size	XS - SM - MD - LG - XL = 190 x 45mm		
		Shock Tune	See Description		Refer to Shock Setup chart for tune information
		Forward Shock Hardware	20 x 8mm		Requires custom hardware. See Shock Hardware chart for information
		Rear Shock Hardware	8 x 40mm	1811007	Requires custom bearing eyelet hardware. See Shock Hardware chart for information
		Approved Shock Fitment	See Description		All Fox rear shock models except Float X2 All Rock Shox rear shock models except Vivid Air All DB Inline models Other rear shock manufacturers' models may fit, but will require fitment on frame to check clearances at full extension and compression
4	Seatpost	Seat Tube Inner Diameter	30.9mm		For seatpost sizing
		Seat Tube Outer Diameter	34.9mm		For seat clamp sizing
		Seat Tube Minimum Insertion	100mm		
			XS = 200 SM = 200		
Seat Tube Machined Ream Depth	MD = 230 LG = 260 XL = 280		For seatpost fitment information, refer to the seatpost fitment section in this manual		

GUIDE DES DIMENSIONS



ITEM NUMBER	CATEGORY	ITEM	DIMENSION	PART NUMBER	DESCRIPTION
5	Crankset	Chainring Size Range	Minimum = 30 Maximum 34T		
		OEM Chainring Size Chain Length	27.5" XS = 32T 116L 29" SM - MD - LG - XL = 32T 118L		
	Chain Guide Kit	See Description	1811008	Canadarm 1.0 + OneUp Upper Guide Complete Kit	
	Chain Guide	OneUp Top Guide	IC0686	OneUp kit only	
	Bashguard	N/A			
	Bottom Bracket	PressFit BB92			
6	Brake	Chainline Range	52 - 55mm		Compatible with Sram and Shimano 52 - 55mm drivetrain systems
		Maximum Rotor Diameter	203mm		
		Maximum Rotor Thickness	2.3mm		
7	Wheel	Wheel Size	XS = 27.5"		This platform is not MX Mullet compatible
			SM - MD - LG - XL = 29"		
		Maximum Tire Width	2.5" 64mm		
8	Rear Hub	Hub Spacing	12 x 148mm		
		Rear Axle	12 x 1.0 x 173mm	3222000	Diameter 12mm x Thread Pitch 1.0mm x Length 173mm
		Complete Hanger Kit	See Description	1812002	Includes Hanger, nut, and washer. For individual parts see exploded diagram
		UDH Transmission	See Description		Frame is UDH and Transmission compatible

VUE EXPLOSÉE



LISTE DES KITS DE PETITES PIÈCES

2025 ELEMENT CARBON						
#	QTY	ITEM	PART NO.	SUPPLIER	REVISION	DESCRIPTION
			1815078	ZCA013		2025 ELEMENT LINK KIT WITH BEARINGS 29" S-XL
18	1	LINK	1095006			MY25 ELEMENT LINK 29", S-XL, 75MM, 6061-T6, HARD BLACK ANODIZED
3	2	BEARING	1805182			ABI 398LLU MAX, 2RS, 8 X 19, 10/11MM,
31	1	SLEEVE	1805047			LOWER LINK SLEEVE, 36 x 8MM ID, NECKED, 6061-T6, HARD BLACK ANO
			1815079	ZCA013		2025 ELEMENT LINK KIT WITH BEARINGS 27.5" XS
19	1	LINK	1095007			MY25 ELEMENT LINK 27.5", XS, 71.5MM, 6061-T6, HARD BLACK ANODIZED
3	2	BEARING	1805182			ABI 398LLU MAX, 2RS, 8 X 19, 10/11MM,
31	1	SLEEVE	1805047			LOWER LINK SLEEVE, 36 x 8MM ID, NECKED, 6061-T6, HARD BLACK ANO
			1812002			2022 HANGER KIT 12 x1.0
14	1	HANGER	1092003	PTW047		MY22 REAR DER. HANGER, M12X1, UDH COMPATIBLE
15	1	HANGER NUT	1801008	PTW047		RMB UDH HANGER NUT, 7075_T6, HARD BLACK ANODIZED
38	1	WASHER	1801009	PTW047		WASHER, 20X24X0.5MM, 304 SS
			1815080	PTW047		2025 ELEMENT CR PIVOT BOLT KIT
5	1	BOLT	1801005			MP BOLT, M10X1.25, L:75, 6MM HEX
36	2	SPACER	1805183			MAIN PIVOT WASHER, 10MM ID X 22MM OD, 6061-T6, HARD BLACK ANODIZED
37	1	WASHER	1800019			WASHERID: 10.2, OD: 15.5, T:1
20	1	MP CHIP	1802013			MAIN PIVOT CHIP, NO KEY
9	1	BOLT	1805167			UPPER LINK BOLT, 61 x 8MM x M1.0, 7075-T6, HARD BLACK ANODIZED
34	2	SPACER	1800039			DO BEARING SPACER, OD:16, ID:8, T:1.75, 6061 ALU
39	2	WASHER	1802011			WASHER ID: 8.2, OD: 13.5, T: 1
8	1	BOLT	1805046			LINK BOLT LOWER, M8 x 1, L: 80mm, 5mm HEX
35	2	SPACER	1805048			LOWER LINK WASHER, 8MM ID, 18.5MM OD, 6061_T6, HARD BLACK ANODIZED
			1815081	ZCA013		2025 ELEMENT CR PIVOT BEARING KIT
2	2	BEARING	1801010			ENDURO 688 LLU MAX 16X8X5
3	2	BEARING	1805182			ABI 398LLU MAX, 2RS, 8 X 19, 10/11MM,
4	2	BEARING	1807042			ENDURO 6900 2RS MAX 22X10X6
30	1	SLEEVE	1802003			TT BEARING SLEEVE. ID: 8, OD: 11.5, L: 32.4
31	1	SLEEVE	1805047			LOWER LINK SLEEVE, 36 x 8MM ID, NECKED, 6061-T6, HARD BLACK ANO
32	1	SLEEVE	1805187			MAIN PIVOT BEARING SLEEVE, OD:15, ID:10, T:39.5
			1812005	PTW047		SHOCK BOLT KIT ELEMENT 2022
6	1	BOLT	1802007			SHOCK BOLT, M8x1.0, L:31.5, 5mm hex
7	1	BOLT	1802008			RIDE 4 BOLT, M8 x 1, OD: 8 mm, L:56, 5 mm Hex
			1811007	ZCA013		SHOCK BEARING EYELET KIT 2021
2	2	BEARING	1801010	PUS098		ENDURO 688 LLU MAX 16X8X5
33	1	SLEEVE	1807028	PTW047		BEARING EYELET CENTRE SLEEVE
10	2	BRG CUP	1800031	PTW047		BEARING EYELET FOR 16X8X5 BRG
11	2	BRG SPACER	1800032	PTW047		EYELET BEARING SPACER, T:6.3, FOR 40 MM LINK WIDTH
			1812007			AXLE KIT BOOST 12X1.0
1	1	AXLE, REAR	3222000	PTW047		REAR AXLE 12X1.0 L:173MM, HARD BLACK ANODIZE
40	1	WASHER	3227006	PTW047		WASHER, 12x19x0.5MM, 304 SS
			1813467	PTW047		NEW HEAD TUBE PANEL KIT (FROM 2023)
16	1	HT PORT COVER	1803012	PTW047		2023 SLAYER CARBON HT PORT COVER, RIGHT
17	1	HT PORT COVER	1803013	PTW047		2023 SLAYER CARBON HT PORT COVER, LEFT
28	2	SCREW, M4X10	1800024-BK	PTW047		C'SUNK SOCKET SCREW, M4x10MM, 10.9 STEEL, BLACK
			1814029	PTW047		RIDE 4 THREADED 10MM CHIP KIT
25	1	RIDE 4 CHIP	1802009			RIDE 4 CHIP, NO THREAD.
26	1	RIDE 4 CHIP	1802010			RIDE 4 CHIP, THREADED, M8 x 1.

LISTE DES KITS DE PETITES PIÈCES

		1815082	ZCA013	2025 ELEMENT PROTECTION KIT
22	1 PROTECTOR	1705001		MY25 ELEMENT CHAINSTAY PROTECTOR, TPE, TEXTURED, 50A
23	1 PROTECTOR	1705002		MY25 ELEMENT SEATSTAY PROTECTOR, TPE10A,
24	1 PROTECTOR	3702014		DOWNTUBE PROTECTOR
		1815083	ZCA013	2025 ELEMENT CR SHIFT HOUSING CLIP KIT
12	1 CLIP	1992035		CABLE P CLIP, 5MM HOLE
29	1 SCREW	1804087		LOW-PROFILE HEAD SCREW, HEX, M5 X 0.8, LENGTH 6MM, STAINLESS, ED BLACK
		1815084	ZCA013	2025 ELEMENT REAR TRIANGLE PLUG KIT
21	1 PLUG	1804020		M5_RIVNUT_PLUG, BLACK PLASTIC

GARANTIE

Votre vélo est assorti d'une garantie contre les défauts de matériaux et de fabrication, dont voici les dispositions:

CATÉGORIE	DURÉE	NOTES
Cadre	5 ans	Triangles avant et arrière, maillons
Quincaillerie	1 an	Pivots, axes, etc.
Pièces de la transmission exposées à l'usure	1 an	Galets, pignons, chaîne
Batterie	2 ans	Si le vélo est entreposé pour trois mois ou plus, charger la batterie au moins tous les trois mois. Sinon, elle risque d'être endommagée.
Autres pièces	Selon la garantie du fabricant	

Toute garantie et service après-vente doivent être gérés par le détaillant Rocky Mountain autorisé qui a vendu le vélo ou le cadre complet. Nous couvrons votre cadre Rocky Mountain à compter de la date d'achat originale de votre nouveau vélo contre les défauts de matériaux et de fabrication, selon le matériau du cadre et le type d'utilisation faite du vélo.

La garantie limitée de Rocky Mountain couvre également les vélos précédemment utilisés à des fins personnelles et commerciales telles que la location (y compris dans les parcs à vélos), les services de messagerie, la police, la sécurité, etc., contre les défauts de matériaux et de fabrication. La garantie limitée s'applique pour le reste de la période de garantie à compter de la date d'achat initiale auprès de Rocky Mountain. Dans de tels cas, la quincaillerie, les roulements, les pivots et les bagues sont exclus de notre politique de garantie. Le reçu de vente original, la confirmation d'enregistrement du vélo ou toute autre preuve d'achat est requis pour toute réclamation.

Pour les vélos 2021 et plus récents, la garantie limitée d'origine est transférable aux propriétaires subséquents. Pour que la garantie limitée s'applique, l'enregistrement du vélo doit être effectué en ligne à la fois par le propriétaire original et par le propriétaire subséquent. La facture originale ne sera pas exigée pour le propriétaire subséquent.

Veillez enregistrer le vélo pour transférer la garantie.

Matériau du cadre/Type d'utilisation

- Carbon fiber: 5 years - Limited*
- Aluminum: 5 years - Limited*
- Please refer to limitations stated below

Autre couverture de garantie contre les défauts de fabrication et de matériaux

- Revêtement - peinture et autocollants : 1 an
 - Quincaillerie du cadre, pivots de suspension et bagues : 1 an
- *Les liens font partie du cadre le vélo pour transférer la garantie.

bikes.com/registration

GARANTIE

NOTES

La garantie n'est plus valide dans les cas suivants:

- Installation et utilisation de composants, pièces ou accessoires non initialement destinés ou compatibles avec le vélo (ou le cadre) tel que vendu.
- Acheter un vélo Rocky Mountain ou utiliser des sites Internet tiers (comme eBay), peu importe ce que dit l'annonce.
- La décoloration de la peinture causée par les effets de la lumière ultraviolette (UV) ou de l'exposition extérieure n'est pas couverte par cette garantie limitée.
- Rocky Mountain ne garantit aucun dommage causé à votre vélo lors de l'installation ou du retrait de tout film protecteur.
- Les rayures ou éclats de peinture causés par la saleté, les cailloux, les débris de la route, le transport en rack, etc. ne sont pas couverts par cette garantie limitée.
- Les dommages au boîtier de pédalier Pressfit causés par un service, des matériaux ou des pièces inappropriés ne sont pas couverts par la garantie limitée Rocky Mountain.

Détail de ce qui n'est pas couvert par la garantie :

1. L'usure normale des pneus, chambres à air, freins, câbles de transmission, plaquettes de frein, roulements, etc., n'est pas couverte par la présente garantie. Votre détaillant Rocky Mountain autorisé vous informera de la nature de ces éléments d'entretien normal.
2. Les dommages consécutifs ou tout dommage causé par un accident (chute), une mauvaise utilisation ou un abus.
3. Un assemblage incorrect ou un manque d'entretien approprié; le sablage, le ponçage, le meulage, le brossage métallique, le limage, le soudage, le brasage, le perçage de trous, l'anodisation, la peinture ou le chromage ne sont pas couverts par notre garantie et peuvent annuler la garantie des autres composants.
4. Vous prenez de grands risques personnels et rendez la garantie nulle, comme indiqué dans le tableau de garantie, lorsque vous roulez sur des terrains extrêmes tels que décrits dans des vidéos de vélo de montagne (c'est-à-dire rouler sur des parcours de style « trial », monter sur des rampes, faire des cascades, rouler sur pistes de BMX, rouler en ville en bas et sur les talus, ou rouler sur d'autres terrains similaires). Il est important de noter que les composants ayant pliés, les cadres, les fourches, les guidons, les tiges de selle, les pédales, les manivelles et les jantes sont des signes d'accidents ou d'abus.
5. La main d'œuvre pour le remplacement ou le changement de pièces n'est pas couvert sous la présente garantie.
6. Rocky Mountain se réserve le droit de réparer ou de remplacer, à sa discrétion, toute pièce considérée comme couverte sous garantie. Veuillez noter que Rocky Mountain fera tout son possible pour assurer, mais ne peut garantir, une correspondance de couleur avec le composant d'origine.

EXCLUSIONS ET LIMITE DES DOMMAGES

LA GARANTIE DE ROCKY MOUNTAIN EST LIMITÉE À LA RÉPARATION OU AU REMPLACEMENT DES PRODUITS ET N'ACCORDE AUCUNE GARANTIE EXPLICITE OU IMPLICITE, LÉGALE OU CONVENTIONNELLE ET DÉCLINE TOUTE GARANTIE IMPLICITE DE QUALITÉ MARCHANDE ET D'ADAPTATION À DES USAGES PARTICULIERS ET ROCKY MOUNTAIN NE SERA EN AUCUN CAS RESPONSABLE POUR LES DOMMAGES DIRECTS OU INDIRECTS, SPÉCIAUX, ACCESSOIRES OU CONSÉCUTIFS MÊME LORSQUE ROCKY MOUNTAIN A ÉTÉ AVISÉ DE TELS DOMMAGES, ET LA RESPONSABILITÉ DE ROCKY MOUNTAIN SERA LIMITÉE À 50,00\$.

EINFÜHRUNG

Beim Element dreht sich alles um Effizienz – du wirst inspiriert sein, die Anstiege zu sprinten und dann von deinem Tempo auf den Abfahrten überrascht sein. Das Element wurde entwickelt, um noch leistungsfähiger zu sein und technische Singletracks besser als je zuvor zu meistern, und bietet ein ausgewogenes Verhältnis zwischen Gewicht, Steifigkeit und Komfort. Die aktualisierte Smoothlink SL-Federung und die Rahmendetails fördern ein präzises Fahrverhalten und machen das Element zum perfekten Bike für alle, die gegen die Uhr fahren, einen Freund verfolgen oder einfach nur einen langen Tag im Sattel verbringen wollen.

Dieses Handbuch enthält wichtige Sicherheits-, Wartungs- und Benutzerinformationen. Lesen Sie es vor der ersten Fahrt mit Ihrem neuen Rocky Mountain-Fahrrad gründlich durch und machen Sie sich damit vertraut. Dieses Material gilt nur für die von Ihnen gewählte Plattform und sollte in Verbindung mit dem Rocky Mountain-Benutzerhandbuch verwendet werden, das Ihrem Fahrrad beiliegt. Bitte lesen Sie das Benutzerhandbuch vor Ihrer ersten Fahrt. Wenn Sie kein Exemplar der Bedienungsanleitung haben, können Sie diese bei Ihrem nächsten autorisierten Rocky Mountain-Händler erhalten.

SCHREDIQUETTE

Rider

Seien Sie immer höflich zu anderen Wanderern. Seien Sie besonders vorsichtig in der Nähe von Haustieren, wie Hunden und Pferden. Lassen Sie anderen Wanderern in jeder Situation Vorfahrt, sowohl beim Aufstieg als auch beim Abstieg.

Wanderwege

Fahren Sie mit dem Fahrrad nur auf Wegen und Pfaden, die für die Fahrradnutzung freigegeben sind. Befolgen Sie alle örtlichen Gesetze und Vorschriften. Wie bei allen anderen Nutzern von Radwegen ist darauf zu achten, dass der Weg und die Umwelt nicht beeinträchtigt werden. Schleudern Sie nicht auf den Wegen und verändern Sie sie nicht.

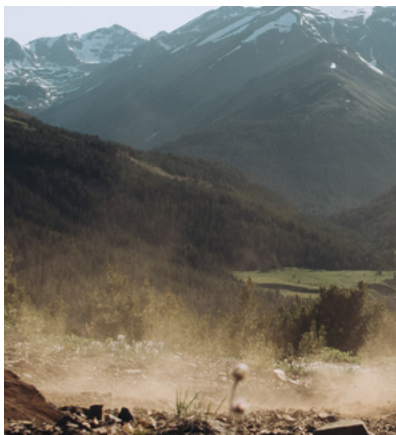
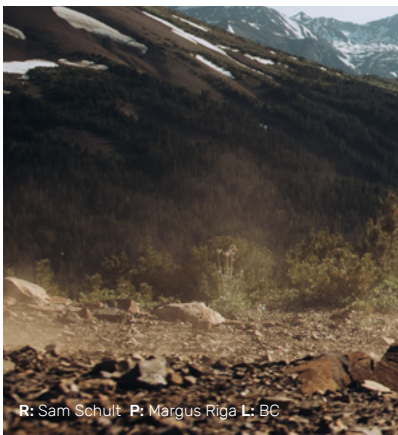

LERNEN SIE IHR FAHRRAD KENNEN



TECHNISCHE EINZELHEITEN

- Das Element der Generation >MY25 verfügt über ein völlig neues Rahmendesign mit unserem Flex Stay- Hinterbau, der die Steifigkeit erhöht und das Rahmengewicht drastisch reduziert..
- Die neue Smoothlink SL-Kinematik zeichnet sich durch eine höhere Sensibilität aus, gepaart mit einer verbesserten Unterstützung während des gesamten Federwegs, mit dem Ziel, die Steifigkeit für eine bessere Kraftübertragung zu erhöhen.
- Die progressive Geometrie und die durchdachten Rahmeneigenschaften bleiben erhalten und sorgen für ein vertrautes, leistungsstarkes Erlebnis im Vergleich zur hochgelobten Vorgängergeneration.
- Erhältlich in einer breiten Palette von Rahmen- und Laufradgrößen. Der XS-Rahmen ist mit 27,5"-Vorder- und Hinterrädern ausgestattet. Die MD-LG-XL Rahmen sind mit 29" Vorder- und Hinterrädern ausgestattet. Diese Plattform ist nicht dazu bestimmt, mit Vokuhila, MX-Einstellung arbeiten.
- Das RIDE-4™-Einstellsystem ermöglicht dem Fahrer eine schnelle Feinabstimmung der Geometrie mit einem einzigen Inbusschlüssel.
- Gedichtete Industrielager am Dämpferauge verbessern das Ansprechverhalten erheblich und sind mit allen im Dämpfern kompatibel.
- Unsere Smoothlink SL-Federung verfügt über einen Flex Stay-Hinterbau, bei dem der gelagerte Drehpunkt am Ausfallende entfällt. Stattdessen haben wir den Drehpunkt zwischen Sitzstrebe und Link mit langlebigen zweireihigen Lagern ausgestattet und verwenden einheitliche, leicht zugängliche Lager für eine einfache Wartung.
- Alle Lager sind zusätzlich durch Abdeckungen geschützt einschließlich gedichteter Distanzscheiben am Hauptlager, um Verschmutzungen durch schwierige Trailbedingungen oder Waschstationen nach der Fahrt zu verhindern.
- Die vollständig geschlossene Innenverlegung bei unseren Carbon-Modellen und die großen gut zugänglichen Leitungsausgänge bei den Alu-Modellen ermöglichen eine einfache Installation von Zughüllen und Leitungen, einschließlich Bremsanlagen im Moto-Style.
- Die Mutter des Hauptlagerbolzens ist mit der des Instincts austauschbar, um unsere Canadaarm und eine OneUp Kettenführung montieren zu können.
- Der Rahmen verfügt über ein komplettes Rahmenprotektor Paket. Durch die geräuschkämpfenden Gummi- Protektoren für Kettenstrebe, Sitzstrebe und Unterrohr. sind alle essentiellen Rahmenteile geschützt.
- Alle Rahmengrößen, mit Ausnahme des XS, können zwei Wasserflaschen im Hauptrahmen aufnehmen. Die untere Flaschenhalterung verfügt über zwei Montagepositionen, um die Platzierung zu optimieren, wenn eine einzelne Flasche bevorzugt wird.

GEOMETRIE UND WICHTIGE ABMESSUNGEN

Das Element ist ein größenpezifisches Rahmendesign mit vielen Details, die die Passform und Geometrie für jeden Fahrer verbessern.

Radgröße

- Der XS-Rahmen ist mit 27,5"-Laufrädern vorne und hinten ausgestattet.
- Die Rahmen SM, MD, LG und XL sind mit 29"-Laufrädern vorne und hinten ausgestattet.
- Diese Plattform ist nicht für die Kompatibilität mit Mullet/MX-Einstellungen vorgesehen.

Ride-4

Das RIDE-4™-Einstellungssystem ermöglicht dem Fahrer/der Fahrerin eine schnelle Feinabstimmung der Geometrie mit einem 5-mm Inbusschlüssel. Vier Konfigurationen sind mit einem Paar rotierender Chips möglich. Wie sich die einzelnen Positionen auf die Geometrie auswirken, wird in der Geometrietabelle dargelegt. Anweisungen zur Einstellung findest du im Abschnitt zu den Rahmeneigenschaften.

BEREIT FÜR JEDEN TRAIL

Das RIDE-4™-Einstellsystem ermöglicht dir eine schnelle Feinabstimmung deiner Geometrie und Aufhängung mit einem einzigen 5 mm-Inbusschlüssel.

Position 1

FLACH

Das tiefere Tretlager und die progressive Federung erhöhen die Stabilität bei hoher Geschwindigkeit. Empfohlen für aggressivere Trails.

Position 3

NEUTRAL

Diese Position bietet eine ausgewogene Mischung von Geometrie und Federungsleistung und ist damit für viele verschiedene Trails geeignet.

Position 4

STEIL

Das höhere Tretlager und die lineare Federung bieten eine bessere Pedalfreiheit, mehr Unterstützung bei der anfänglichen Federkonstante und eine Position auf dem Rad, die besser zum Klettern geeignet ist.

GEOMETRIE UND DIMENSIONIERUNG

Rahmengröße

Diese Tabelle ist nur ein grober Richtwert. Die Proportionen des Fahrers, sein Fahrstil und seine persönlichen Vorlieben spielen bei der Wahl der richtigen Fahrradgröße eine Rolle. Im Allgemeinen haben Fahrräder mit kürzerem Reach ein dynamischeres, lebendigeres Fahrgefühl. Längere Fahrräder haben eher ein stabileres, gedämpftes Fahrgefühl. Rocky Mountain empfiehlt immer eine Probefahrt und eine professionelle Fahrrad Anpassung bei einem autorisierten Händler.

CM	147,5	150	152,5	152,5	155	157,5	160	162,5	165	167,5	170	172,5	175	177,5	180	183	185,5	188	190,5	193	195,5	198	
FT-IN	4'7"	4'8"	4'9"	5'0"	5'1"	5'2"	5'3"	5'4"	5'5"	5'6"	5'7"	5'8"	5'9"	5'10"	5'11"	6'	6'1"	6'2"	6'3"	6'4"	6'5"	6'6"	
		XS				SM				MD				LG				XL					
XS	█																						
SM		█																					
MD			█																				
LG				█																			
XL					█																		



R: Celeste Pomerantz P: Niklas Wallner L: Norway

GEOMETRIEDATEN

RAHMENGRÖSSE	XS	SM	MD	LG	XL
Laufradgröße	27.5			29	
Steuerrohrwinkel (Grad)	64,7	65	65	65	65
Sitzrohrwinkel (Grad)	75,7	76	76	76	76
Sitzrohrlänge (mm)	355	380	420	445	480
Oberrohrlänge (mm)	542	577	605	632	664
Steuerrohrlänge (mm)	90	105	115	125	135
Hinterbaulänge (mm)	426	436	436	436	436
Tretlagerabsenkung (mm)					
Schritthöhe (mm)	769	810	808	806	804
Radstand (mm)	1127	1173	1202	1231	1265
Reach (mm)	397	425	450	475	505
Stack (mm)	561	606	615	624	633
<hr/>					
Steuerrohrwinkel (Grad)	64,9	65,2	65,2	65,2	65,2
Sitzrohrwinkel (Grad)	75,9	76,2	76,2	76,2	76,2
Sitzrohrlänge (mm)	355	380	420	445	480
Oberrohrlänge (mm)	542	577	604	631	663
Steuerrohrlänge (mm)	90	105	115	125	135
Hinterbaulänge (mm)	426	435	435	435	435
Tretlagerabsenkung (mm)					
Schritthöhe (mm)	770	811	809	807	805
Radstand (mm)	1127	1173	1202	1231	1265
Reach (mm)	400	427	452	477	507
Stack (mm)	563	607	616	625	635

GEOMETRIEDATEN

RAHMENGRÖSSE	XS	SM	MD	LG	XL
Laufradgröße	27.5			29	
Steuerrohrwinkel (Grad)	65,3	65,5	65,5	65,5	65,5
Sitzrohrwinkel (Grad)	76,1	76,5	76,5	76,5	76,5
Sitzrohrlänge (mm)	355	380	420	445	480
Oberrohrlänge (mm)	541	576	603	631	663
Steuerrohrlänge (mm)	90	105	115	125	135
Hinterbaulänge (mm)	425	435	435	435	435
Tretlagerabsenkung (mm)	21	40	40	40	40
Schritthöhe (mm)	771	812	810	809	807
Radstand (mm)	1127	1173	1202	1231	1265
Reach (mm)	403	430	455	480	510
Stack (mm)	565	609	618	627	636
Position 3 Neutral					
Steuerrohrwinkel (Grad)	65,5	65,8	65,8	65,8	65,8
Sitzrohrwinkel (Grad)	76,5	76,8	76,8	76,8	76,8
Sitzrohrlänge (mm)	355	380	420	445	480
Oberrohrlänge (mm)	541	575	603	630	662
Steuerrohrlänge (mm)	90	105	115	125	135
Hinterbaulänge (mm)	425	435	435	435	435
Tretlagerabsenkung (mm)	19	36	36	36	36
Schritthöhe (mm)	772	813	811	810	808
Radstand (mm)	1127	1173	1202	1231	1265
Reach (mm)	405	433	458	483	513
Stack (mm)	566	610	619	628	637
Position 4 Steep					

GEOMETRIE UND GRÖSSENANPASSUNG

Kompatibilität Absenkbarer Sattelstützen

Abgesenkte Sattelstützen spielen eine wichtige Rolle für die Passform und den Komfort des Fahrrads. Im Folgenden finden Sie die kritischen Dimensionen und Messungen, die Sie in der OEM Post-Konfiguration sowie einige der möglichen Optionen, wenn ein Aftermarket Dropper Sattelstütze installiert ist.

Die Tabelle zeigt die Passform der Sattelstütze bei voll ausgefahrenem Federweg. Dies ermöglicht es Ihnen, die niedrigste oder höchste Position zu bestimmen, in der Ihre Sattelstütze für die richtige Höhe in einer sitzenden Pedalstellung eingestellt werden kann. Die Tabelle hilft Ihnen auch dabei, die richtige Größe der Sattelstütze zu bestimmen, wenn die OEM-Sattelstütze nicht die gewünschte Größe hat. Bitte beachten Sie, dass die angegebenen Maße von der Mitte des Tretlagers bis zur Oberkante des OEM-Sattels reichen. Die Länge der Kurbelgarnitur kann die Sitzposition beeinflussen und sollte ebenfalls berücksichtigt werden, wenn diese Komponente geändert wird.

Verwendung der Tabelle

1. Messen Sie Ihre aktuelle Sattelhöhe von der Mitte des Tretlagers bis zur Oberseite des Sattels direkt über der Sattelstütze.
2. Wählen Sie Ihr gewünschtes Sattelstützenmodell, den Hub/Absenkbereich und den Rahmen aus.
3. Stellen Sie sicher, dass Ihr Maß zwischen der minimalen und maximalen Einbaulänge liegt, die in der Tabelle angegeben ist.

Beispiel: Ich habe 795 mm an meinem aktuellen Fahrrad gemessen. Wenn ich die OneUp V3 mit 210 mm Hub-Option und einem LG Carbon-Rahmen wähle, sehe ich, dass diese Kombination aus Hub und Rahmengröße passt, da die minimalen und maximalen möglichen Maße 728mm bis 860 mm betragen.

MODELL	OEM-SPEZIFIKATION PRORAHMENGROSSE	VERSTELLWEG	RAHMENGROSSE	CARBON				
				XS	SM	MD	LG	XL
X Fusion Manic	XS - SM	125	Länge Sitzrohr	355	380	420	445	480
			Minimum Einfügung	100	100	100	100	100
			Maximale Einfügung	200	200	230	260	280
		125	Mindesthöhe des Sattels	599	624	640	665	700
			Maximale Sattelhöhe	671	696	736	761	796
			MD	Mindesthöhe des Sattels	663	688	698	693
	150	Maximale Sattelhöhe		725	750	790	815	850
		LG		Mindesthöhe des Sattels	707	732	742	737
	170		Maximale Sattelhöhe	739	764	804	829	864
		XL	200	Mindesthöhe des Sattels	772	797	807	802
	200		Mindesthöhe des Sattels	784	809	849	874	909
	2025 Fox Transfer *Der Federweg ist einstellbar und kann in 5mm-Schritten bis zu 25mm reduziert werden.	XS - SM	120	Länge Sitzrohr	574	599	621	646
120			Minimum Einfügung	646	671	711	736	771
MD		150	Maximale Einfügung	639	664	674	677	712
		150	Mindesthöhe des Sattels	711	736	776	801	836
LG		180	Maximale Sattelhöhe	704	729	739	734	749
		180	Mindesthöhe des Sattels	776	801	841	866	901
XL		210	Maximale Sattelhöhe	769	794	804	799	814
		200	210	Mindesthöhe des Sattels	841	866	906	931

GEOMETRIE UND GRÖSSENANPASSUNG

MODELL	OEM-SPEZIFIKATION PRORAHMENGROSSE	B	RAHMENGROSSE	CARBON				
				XS	SM	MD	LG	XL
Reverb AXS *Mindestens 80 mm Mindesteinstecktiefe Der Rahmen fordert aber 100 mm	XS - SM	125	Länge Sitzrohr	587	612	652	677	712
		125	Minimum Einfügung	687	712	752	777	812
	MD	150	Maximale Einfügung	637	662	677	702	737
		150	Mindesthöhe des Sattels	737	762	802	827	862
	LG - XL	175	Maximale Sattelhöhe	687	712	722	727	762
		175	Maximale Sattelhöhe	787	812	852	877	912
OneUp V3 Dropper *Der Hub ist einstellbar und kann bis zu 20 mm in 10-mm-Schritten reduziert werden.	XS - SM	120	Länge Sitzrohr	560	585	625	650	685
		120	Minimum Einfügung	645	670	710	735	770
	MD	150	Maximale Einfügung	620	645	655	675	710
		150	Mindesthöhe des Sattels	705	730	770	795	830
	LG	180	Maximale Sattelhöhe	680	705	715	710	735
		180	Mindesthöhe des Sattels	750	775	815	840	875
	XL	210	Maximale Sattelhöhe	740	765	775	770	785
		210	Mindesthöhe des Sattels	795	820	860	885	920
		240	Maximale Sattelhöhe	810	835	845	840	855
		240	Mindesthöhe des Sattels	850	875	915	940	975
Revive 3 Dropper *Der Hub ist einstellbar und kann in 5mm-Schritten bis zu 30mm reduziert werden, je nach Option.		125	Länge Sitzrohr	581	606	627	652	687
		125	Minimum Einfügung	680	705	745	770	805
		160	Maximale Einfügung	651	676	686	687	722
		160	Mindesthöhe des Sattels	730	755	795	820	855
		185	Maximale Sattelhöhe	701	726	736	731	747
		185	Mindesthöhe des Sattels	780	805	845	870	905
		213	Maximale Sattelhöhe	766	791	801	796	811
		213	Mindesthöhe des Sattels	815	840	880	905	940

SPEZIFIKATIONEN UND ABMESSUNGEN

ZS44|56 Press-In Headset

Alle Rahmen sind mit ZS44|56 Press-In Headsets ausgestattet

Der Carbon-Element-Rahmen verwendet Steuersatzschalen im Press-in-Stil. Spezielle Steuersatzwerkzeuge sind erforderlich, um die Schalen im Rahmen zu entfernen und zu installieren. Die Steuersätze für die Carbonrahmen werden von FSA hergestellt und sind oft als Modell No.57e oder Orbit 1.5zs gekennzeichnet. Sie verwenden Standard-FSA-Montageteile wie Lager und Laufringe, um sicherzustellen, dass der Austausch von Verschleißteilen ein schmerzloser Prozess ist.

Assembly Element Carbon-Legierung Steuersatz

Notes Das Element verwendet eine mit rostfreien Lagern und 5,3 mm hoher Abdeckkappe ausgestattete Variante des üblichen FSA-Steuersatzes No.57e / Orbit 1.5ZS.

QTY	ARTIKEL	TEIL NUMMER	DESCRIPTION
1	Kopfhörer	121-0501	FSA Part Number No.57E - Orbit 1.5ZS Steuersatz mit Standardlagern und 8mm Abdeckkappe
1	Kopfhörer	H018200000E401	FSA Part Number No.57E - Orbit 1.5ZS Steuersatz mit rostfreien Lagern und 5,3 mm Top-Cap
2	Oberes Steuerrohr	N/A	ZS44 Standard
N/A	Unteres Steuerrohr	N/A	ZS56 Standard
1	Rubber O-Ring	160-7042	FSA Top Cap Inner Rubber O-Ring
1	Top Cap	161-4430	FSA 5.3mm Top Cap inkl. Gummidichtung
1	Split Race	160-7626	FSA 1 1/8" Steuersatz Kompressionsring
1	Lager	160-6465	FSA Edelstahl ACB 1 1/8" 36°x45° Lager
1	Lager	160-67400E	FSA Edelstahl ACB 1,5" 36°x45° Lager
1	Crown Race	160-5536	FSA 1,5" Krone Laufrad

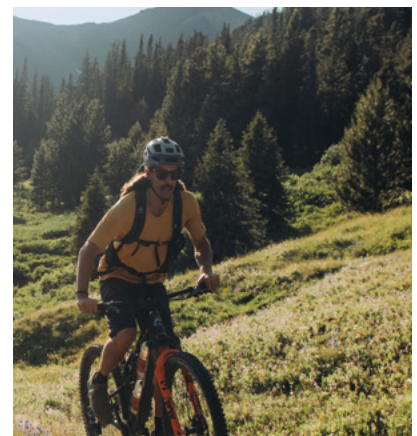
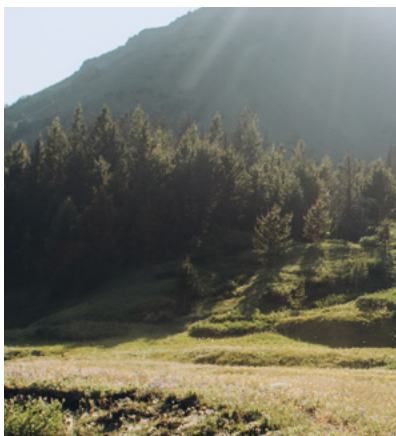
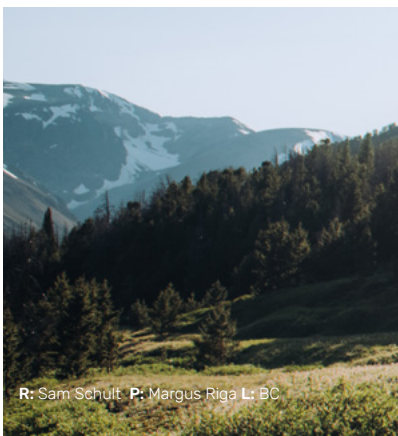

UDH HANGER

Ihr neuer Rahmen ist mit dem UDH-Gehänge von Sram kompatibel. Für die Montage eines UDH-Aufhängers sind keine speziellen Anweisungen für den Rahmen erforderlich. Für die korrekte Montage des Sram UDH-Gehäuses lesen Sie bitte die mit dem Gehänge gelieferte Anleitung von Sram.

EYELETBEARING UND DÄMPFERHARDWARE

Ihr Rahmen ist mit Cartridge-Lagern in der hinteren Öse ausgestattet, die für eine bessere Nachgiebigkeit bei kleinen Unebenheiten sorgen. Diese Lager werden von Schalen getragen, die einen sehr festen Presssitz in der Dämpferwelle haben. Wenn Sie Ihr Federbein warten lassen, empfehlen wir Ihnen dringend, diese Komponenten zu entfernen, da die Federungswerkstätten nicht garantieren können, dass sie zurückgeschickt werden.

Die vordere Dämpferaufnahme verwendet Standard Dämpferbuchsen, die vom Dämpferhersteller bereitgestellt werden. In der nachfolgenden Tabelle finden Sie technische Informationen zu allen Dämpferbauteilen, Diagramme als Referenz und Anleitungen zum entfernen des Eyeletbearings-Systems.

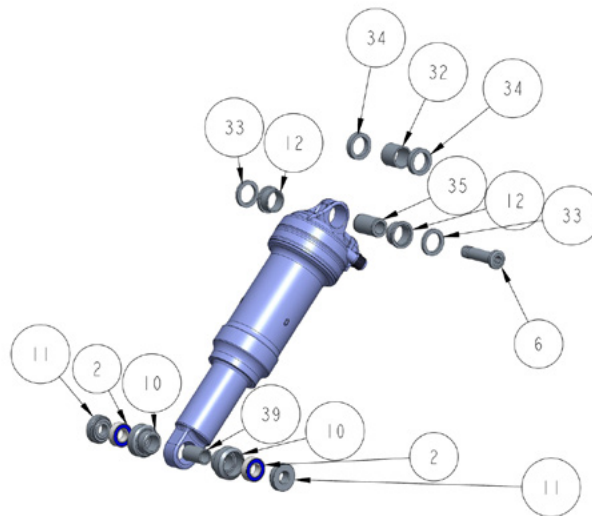

Assembly *Element Forward Shock Hardware*
 Dimensions *20x8mm (Stoßdämpferbolzenbreite x Beschlagsdurchmesser)*

QTY	ARTIKEL	TEIL NUMMER	BESCHREIBUNG
1	Fox Komplettpaket	803-03-326	FOX Mounting Hardware - 9 Piece AL 8mm x 20/0.787
1	Rock Shox Komplettpaket	11.4118.091.806	ROCK SHOX HARDWARE 8 x 20.0

Profi-Tipp: Das Fox Complete Kit ist mit den Rock Shox Dämpferösen kompatibel. Entfernen Sie die Teflonbuchse von der Rock Shox Öse, bevor Sie das Fox Kit installieren.

EYELETBEARING UND DÄMPFERHARDWARE

Entfernen der Eyeletbearings

Gehen Sie folgendermaßen vor, um das System zu entfernen

- Verwenden Sie den Rocky Mountain Bearing Eyelet Tool Kit (Teilenummer 1810031)
- Montieren Sie das Hutteil auf einer Seite des Lagerauges
- Installieren Sie dann eines der Werkzeuge zum Entfernen der Schale über der Lagerschale mit dem montierten Hutteil.
- Drehen Sie die M8-Schraube fest gegen das Hutteil.
- Setzen Sie das andere Werkzeug zum Entfernen der Lagerschale auf die andere Lagerschale.
- Drehen Sie die M8-Schraube ganz ein, bis sie auf der anderen Seite zu drücken beginnt. die andere Seite drückt. Sie berührt die Innenseite des Deckels Stücks.
- Fädeln Sie weiter, bis einer der Becher vollständig herausgedrückt ist.
- Führen Sie nun das Eintreibwerkzeug durch die Dämpferöse und stützen Sie es fest gegen die Lagerschale, die noch in die Dämpferöse gedrückt Dämpferöse gedrückt wird.
- Hämmern Sie sanft, aber fest auf das Eintreibwerkzeug, bis die Lagerschale vollständig aus der Stoßdämpferöse entfernt ist.

Wenn Sie nicht über das Rocky Mountain Bearing Eyelet Tool Kit verfügen, verwenden Sie einen Blindabzieher.:

- Verwenden Sie einen Blindlagerabzieher (8 mm Verlängerung), um beide Lager zu entfernen. Montieren Sie das Hutstück auf einer Seite der Lageröse
- Entfernen Sie die mittlere Hülse.
- Verwenden Sie den Blindlagerabzieher (10 mm Verlängerung), um die leeren Lagerschalen zu entfernen.

HINWEIS: Der Innendurchmesser der Becher beträgt 11 mm, was bedeutet, dass die 12-mm-Verlängerung nicht passt (also nicht erzwingen); verwenden Sie die 10-mm-Verlängerung.

Für den Einbau der neuen Lagerschalen verwenden Sie eine Lagerpresse oder einen Schraubstock mit weichen Backen. Achten Sie darauf, dass Sie auf den äußeren Rand der Lagerschalen drücken und vergessen Sie nicht die mittlere Distanzhülse zwischen den Lagerschalen.

DÄMPFERABSTIMMUNG

Bevor Sie Ihre Dämpfereinstellungen ändern, sollten Sie sich über die verschiedenen Einstellmöglichkeiten informieren.

Einstellung der Federhärte

Je nach Dämpfermodell müssen Sie möglicherweise die Schraubenfederrate oder den Luftdruck anpassen, um den empfohlenen Durchhang für Instinct zu erreichen. In der nachstehenden Tabelle finden Sie Empfehlungen für Schraubenfederraten und Luftdrücke.

Zugstufe

Die Einstellung der Zugstufe regelt, wie schnell die Federung nach einem Stoß wieder voll ausfedert. Wenn Sie die Zugstufe zu stark einstellen, bewegt sich die Gabel oder das Federbein zu langsam und sinkt bei wiederholten Stößen immer tiefer in den Federweg ein, was sich rau anfühlt. Bei einer zu geringen Einstellung kann die Federung zu schnell zurückfedern, was zu einem Verlust von Traktion und Kontrolle führt.

- Low Speed Rebound (LSR) bezieht sich auf die niedrige Gabel- oder Dämpfergeschwindigkeit, nicht auf die Fahrgeschwindigkeit. Diese Einstellung beeinflusst die Zugstufe im ersten Teil des Federwegs.
- High Speed Rebound (HSR) bezieht sich auf die hohe Gabel- oder Dämpfergeschwindigkeit, nicht auf die Rückwärtsgeschwindigkeit. Diese Einstellung beeinflusst die Zugstufe im zweiten Teil des Federwegs.

Druckstufe

Die Druckstufenregelung steuert, wie schnell sich Ihre Federung beim Aufprall auf eine Bodenwelle in den Federweg bewegt. Wenn Sie die Druckstufe zu stark einstellen, bewegt sich die Gabel oder das Federbein zu langsam und die Kraft des Aufpralls wird zu sehr vom Reifen und Ihrem Körper absorbiert. Bei zu geringer Einfederung bewegt sich die Gabel oder das Federbein zu schnell, wodurch sich das Fahrrad träge und unempfindlich anfühlt.

Die Low-Speed-Compression (LSC) bezieht sich auf die niedrige Geschwindigkeit der Gabel oder des Dämpfers, nicht auf die Trail-Geschwindigkeit. Sie steuert die Gewichtsverlagerung des Fahrers, das Pumpen durch das Gelände, G-outs und andere langsame Eingaben. Zu viel LSC führt zu einem härteren Fahrgefühl; zu wenig LSC führt zu einem zu weichen und unansprechenden Fahrgefühl. LSC ist über den gesamten Federwegsbereich wirksam.

High Speed Compression (HSC) bezieht sich auf eine hohe Gabel- oder Stoßdämpfergeschwindigkeit, nicht auf die Geschwindigkeit auf dem Trail. Sie steuert die Fähigkeit, große Stöße, wie z. B. Felsen und Bodenwellen, zu absorbieren. Zu viel HSC führt zu einem härteren Fahrgefühl beim Fahren auf schnellen, rauen Trails mit vielen großen Unebenheiten; zu wenig HSC führt zu unzureichender Unterstützung beim Auftreffen auf diese großen Unebenheiten und kann dazu führen, dass Sie Ihren gesamten Federweg nutzen.

Hydraulische Durchschlagschutz

Hydraulic Bottom Out (HBO) bezieht sich auf die Bottom-Out-Resistenz, die einige Dämpfer in Kombination mit einem externen Ausgleichsbehälter bieten können. Dies wirkt sich auf die letzten 20 % des Federwegs aus und wird bei großen Stößen verwendet, bei denen das Fahrrad durchschlagen kann.

DÄMPFERABSTIMMUNG

In den nachstehenden Tabellen finden Sie alle OEM-Dämpferkonfigurationen für das Element. Aufgrund der großen Anzahl von Dämpfern, die mit dem Element kompatibel sind, können wir keine Setup-Anleitungen für Modelle außerhalb der OEM-Spezifikationen bereitstellen.

Tipps und Tricks zur Federung

Wenn Sie Ihr Fahrwerk einstellen, notieren Sie sich Ihre Einstellungen, damit Sie darauf zurückgreifen können. Noch besser: Verwenden Sie eine Online-Tabelle auf Ihrem Telefon!

Der Ausbau des Dämpfers am Element mit seiner Smoothlink SL-Federung ist einfach, kann aber ein paar Tipps und Tricks erfordern. Der Hauptunterschied zu unserem Smoothlink SL-Hinterbau und seinem einteiligen Design besteht darin, dass die Sitze statisch ausgelegt sind und bei 25 % Durchhang 0 Federkraft bieten. Wenn Sie den Dämpfer ausbauen, wird sich der Hinterbau in seine natürliche Ruheposition zurückbewegen wollen. Der Wiedereinbau des Dämpfers erfordert ein geringes Maß an Biegung, um die letzte verbleibende Schraube an der Sitzstreben- oder Dämpferbefestigung in eine Linie zu bringen.

Hier ist eine Schritt-für-Schritt-Anleitung für den Ausbau. Schalten Sie auf das kleine Ritzel der Kassette herunter und verriegeln Sie den Schaltkäfig, wenn möglich.

1. Dämpfer im Link platzieren
 - a. Die Abstandshalter für die Lageraugen auf jeder Seite werden herausfallen, daher sollten Sie eine Hand unter den Bereich der Lageraugen legen, um sie an ihrem Platz zu halten.
2. Setzen Sie die hintere Stoßdämpferschraube ein.
 - a. Bei Bedarf können Sie die Ride4-Späne auf beiden Seiten der Verbindung entfernen, um die Schraube zuerst mit dem Lagerauge in eine Linie zu bringen. Sobald der Bolzen halb in das Lagerauge eingeführt ist, wird die Ausrichtung des Ride4-Chips viel einfacher.
3. Vordere Stoßdämpferschraube einbauen.
 - a. In diesem Schritt müssen Sie das hintere Dreieck vorsichtig vorspannen, bis die vordere Dämpferöse mit dem Loch für die Dämpferbefestigung ausgerichtet ist.
4. Sobald beide Stoßdämpferbolzen installiert und teilweise mit Gewinde versehen sind, fügen Sie dem hinteren Dreieck eine Vorspannung hinzu, um sicherzustellen, dass alle Teile an ihrem Platz sind, und ziehen Sie beide Bolzen fest.
5. Ziehen Sie alle Teile nach Vorgabe an. Bitte beachten Sie unsere Explosionszeichnung für Details.

Montage *Element Hinteres Stoßdämpfer-Lagerauge*

Dimensions *40x8mm (Breite x Beschlagsdurchmesser)*

QTY	ARTIKEL	TEIL NUMMER	BESCHREIBUNG
1	RMB Complete Kit	1811007	8 x 40mm Shock Bearing Eyelet Kit
2	Bearing	1801010	ENDURO 688 LLU MAX 16X8X5
2	Bearing Cup	1800031	BEARING EYELET FOR 16X8X5 BRG
1	Sleeve	1807028	BEARING EYELET CENTRE SLEEVE
2	Bearing Spacer	1800032	EYELET BEARING SPACER, T:6.3, FOR 40 MM LINK WIDTH
1	Rock Shox Complete Kit	11.4118.091.806	ROCK SHOX HARDWARE 8 x 20.0

Montage *Element Forward Shock Hardware*

Dimensions *20x8mm (Stoßdämpferstiftbreite x Beschlagsdurchmesser)*

QTY	ARTIKEL	TEIL NUMMER	BESCHREIBUNG
1	Fox Complete Kit	803-03-326	FOX Mounting Hardware - 9 Piece AL 8mm x 20/0.787"
1	Rock Shox Complete Kit	11.4118.091.806	ROCK SHOX HARDWARE 8 x 20.0

DÄMPFERABSTIMMUNG

2025 ELEMENT FOX FLOAT AIR SHOCK

SHOCK DIMENSIONS ALLE GRÖSSEN = 190 X 45MM

SHOCK TUNE XS - SM = NO VOLUME SPACERS, CM, RM, CMF
MD - XL = 0.1 VOLUME SPACER X 1, CM, RF, CMF

NOTES *ZÄHLEN SIE KLICKS VON GESCHLOSSEN: 0 KLICKS = GESCHLOSSEN*

RIDER GEWICHT	DRUCK	SHOCK SAG	LSR	HSR	LSC	HSC
100lbs 45kg	100psi 6.9bar		10			
110lbs 50kg	110psi 7.6bar		10			
120lbs 55kg	120psi 8.3bar		10 - 9			
130lbs 59kg	130psi 9bar		9			
140lbs 64kg	140psi 9.7bar		9 - 8			
150lbs 68kg	150psi 10.3bar		8			
160lbs 73kg	160psi 11bar		8 - 7			
170lbs 77kg	170psi 11.7bar	Alle Größen 12 - 14mm	7	Nicht verfügbar	Start Öffnen Anpas- sen an Vorliebe	Nicht verfügbar
180lbs 82kg	180psi 12.4bar		7 - 6			
190lbs 86kg	190psi 13.1bar		6			
200lbs 91kg	200psi 13.8bar		6 - 5			
210lbs 95kg	210psi 14.5bar		5			
220lbs 100kg	220psi 15.2bar		5 - 4			
230lbs 105kg	230psi 15.9bar		4			
240lbs 109kg	240psi 16.5bar		4 - 3			
250lbs 114kg	250psi 17.2bar		3			

2025 ELEMENT ROCK SHOX DELUXE AIR SHOCK

SHOCK DIMENSIONS ALLE GRÖSSEN = 190 X 45MM

SHOCK TUNE XS - MD = 0L0 PRL 32SN
LG - XL = 0L1 PRM 32SN

NOTES *ZÄHLEN SIE KLICKS VON GESCHLOSSEN: 0 KLICKS = GESCHLOSSEN*

RIDER GEWICHT	DRUCK	SHOCK SAG	LSR	HBO	LSC	HSC
100lbs 45kg	130psi 9bar		6 - 5			
110lbs 50kg	140psi 9.7bar		6 - 5			
120lbs 55kg	150psi 10.3bar		5			
130lbs 59kg	160psi 11bar		5 - 4			
140lbs 64kg	170psi 11.7bar		5 - 4			
150lbs 68kg	180psi 12.4bar		4			
160lbs 73kg	190psi 13.1bar		4 - 3			
170lbs 77kg	200psi 13.8bar	Alle Größen 12 - 14mm	4 - 3	Nicht verfügbar	Start Öffnen Anpassen an Vorliebe	Nicht verfügbar
180lbs 82kg	210psi 14.5bar		3			
190lbs 86kg	220psi 15.2bar		3 - 2			
200lbs 91kg	230psi 15.9bar		3 - 2			
210lbs 95kg	240psi 16.5bar		2			
220lbs 100kg	250psi 17.2bar		2 - 1			
230lbs 105kg	260psi 17.9bar		2 - 1			
240lbs 109kg	270psi 18.6bar		1			
250lbs 114kg	280psi 19.3bar		1 - Closed			

DÄMPFERABSTIMMUNG

2025 ELEMENT ROCK SHOX SIDLUXE AIR SHOCK

SCHOCK
ABMESSUNGEN ALLE GRÖSSEN = 190 X 45MM

SCHOCK-STIMMUNG
XS - SM = S1 R81 C27 X8SN
MD = S1 R85 C30 X8SN
LG - XL = D1 R85 C33 X8SN

NOTES *ZÄHLEN SIE KLICKS VON GESCHLOSSEN: 0 KLICKS = GESCHLOSSEN*

RIDER GEWICHT	DRUCK	SHOCK SAG	LSR	HBO	LSC	HSC
100lbs 45kg	150psi 10.3bar		7 - 6			
110lbs 50kg	160psi 11bar		7 - 6			
120lbs 55kg	175psi 12bar		7 - 6			
130lbs 59kg	185psi 12.8bar		6 - 5			
140lbs 64kg	195psi 13.4bar		6 - 5			
150lbs 68kg	205psi 14.1bar		6 - 5			
160lbs 73kg	220psi 15.2bar		6 - 5			
170lbs 77kg	230psi 15.9bar	Alle Größen 12 - 14mm	5 - 4	Nicht verfügbar	Start Open Anpassen an Präferenz	Nicht verfügbar
180lbs 82kg	240psi 16.5bar		5 - 4			
190lbs 86kg	250psi 17.2bar		5 - 4			
200lbs 91kg	265psi 18.3bar		3 - 4			
210lbs 95kg	275psi 19bar		3 - 4			
220lbs 100kg	290psi 20bar		3 - 4			
230lbs 105kg	305psi 21bar		2 - 3			
240lbs 109kg	320psi 22bar		2 - 3			
250lbs 114kg	330psi 22.8bar		2 - 3			

ZUGVERLEGUNG HOW-TO

Diese Anleitung gilt nur für den Carbon-Element-Rahmen.

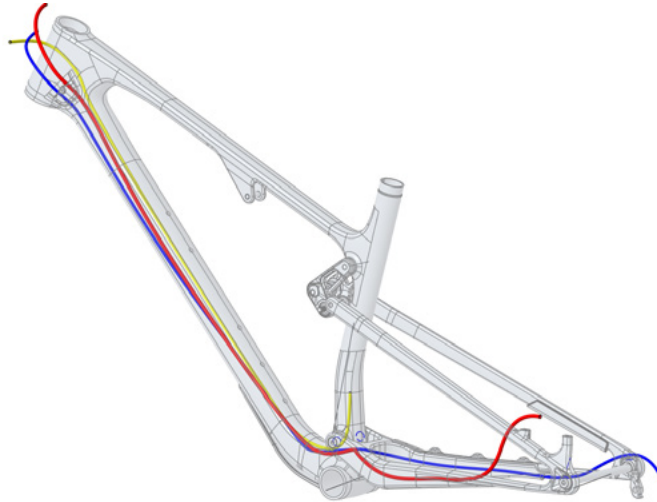

Wenn Sie das Hinterrad und den Hauptdrehbolzen entfernen, können Sie das hintere Dreieck abnehmen und das Gehäuse im Bereich zwischen dem hinteren und dem vorderen Dreieck besser erreichen.

Die Rohr-in-Rohr-Kanäle in der Kettenstrebe können manchmal sehr eng sein, vor allem bei den Kurven, die sie manchmal durchlaufen müssen. Sprühen Sie Seifenwasser als Schmiermittel in die Öffnung, um das Einpassen des Gehäuses von einem Ende zum anderen zu erleichtern. Verwenden Sie kein Fett oder Öl, denn das hinterlässt eine Sauerei und zieht Schmutz an.

CHSELN/MONTIEREN DER SCHALTZUGHÜLLE

Wenn Sie die alte Schaltzughülle ersetzen, entfernen Sie diese aus dem Rahmen und schneiden Sie ein neues Stück in der gleichen Länge zu. Wenn Sie die alte Hülle nicht mehr haben, schätzen Sie die benötigte Länge und schneiden Sie ein etwas längeres Stück ab.

- 1.** Entfernen Sie die Abdeckung des Kopfrohranschlusses auf der Nicht-Antriebsseite.

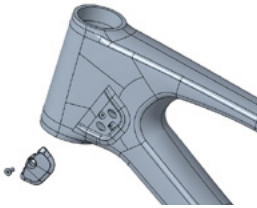

- 2.** Beginnen Sie am hinteren Ende des Fahrrads mit dem Einführen des Gehäuses in die Kabelöffnung an der antriebsseitigen Kettenstrebe. Drücken Sie das Gehäuse nach vorne und drehen Sie es gleichzeitig, bis es am vorderen Ende der Kettenstrebe herauskommt.

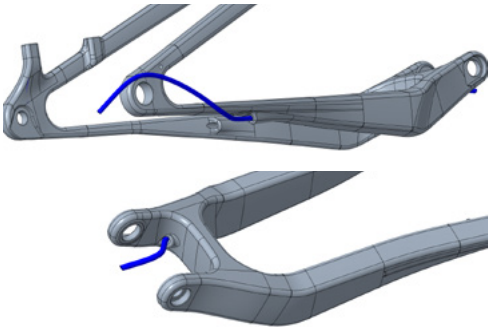

- 3.** Führen Sie das Gehäuse in die Gehäuseöffnung oberhalb des Tretlagers. Achten Sie darauf, dass Sie das Schaltwerkgehäuse in die antriebsseitige Öffnung einsetzen.

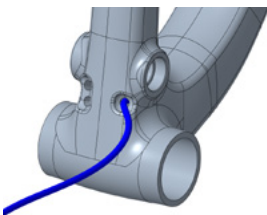

- 4.** Schieben Sie das Kabel von hinten, bis es an der Steuerrohröffnung herauskommt.

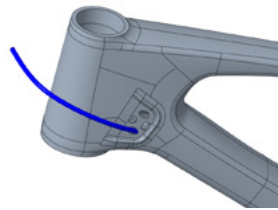

- 5.** Sobald das Gehäuse vollständig zwischen dem Schalthebel und dem Schaltwerk installiert ist, setzen Sie den Steuerrohranschluss wieder ein.

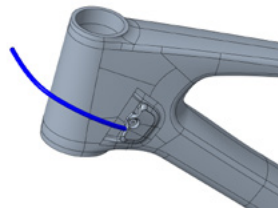

- 6.** Klemmen Sie das hintere Schlaufengehäuse mit der P-Klammer und der M5-Schraube an der Sitzstrebe fest.

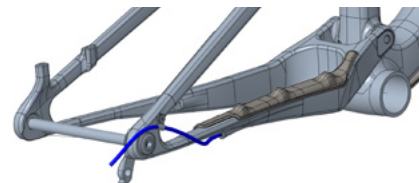

AUSTAUSCH/EINBAU DER KABELHÜLLE DER SATTELSTÜTZE

Wenn Sie das alte Gehäuse ersetzen, entfernen Sie es und schneiden Sie ein neues Stück in der gleichen Länge zu. Wenn Sie das alte Stück nicht mehr haben, schätzen Sie die benötigte Länge und schneiden Sie ein etwas längeres Stück ab.

- 1.** Abdeckung der Kopfrohröffnung auf der Antriebsseite entfernen.

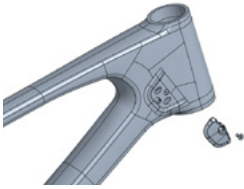

- 2.** Carbon: Beginnen Sie an der Steuerrohröffnung und führen Sie das Gehäuse in die untere Gehäuseöffnung ein. Drücken Sie das Gehäuse nach vorne, bis es am Sitzrohr herauskommt.

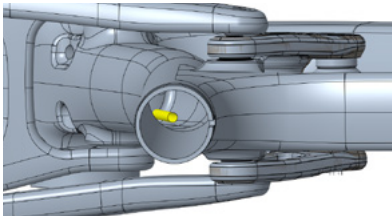
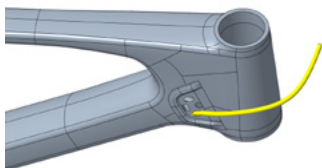

- 3.** Föhren Sie die Installation der Sattelstütze gemäß den Anweisungen des Sattelstützenherstellers durch.

- 4.** Wenn die Sattelstütze korrekt montiert ist, bringen Sie den Steuerrohranschluss wieder an.

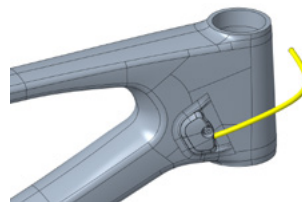

ERSETZEN/INSTALLIEREN DER HINTEREN HYDRAULISCHEN BREMSLEITUNG

1. Entfernen Sie je nach Lage der hinteren Bremsleitung die Abdeckung des Steuerrohranschlusses auf der Antriebs- oder Nicht-Antriebsseite. Falls

Reguläres Routing = Nicht-Antriebsseite

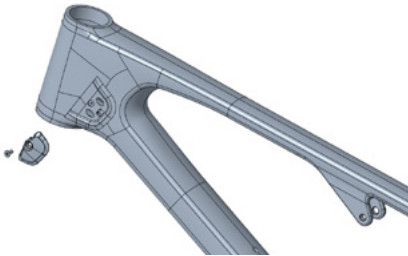

Moto | UK-AUS Verlegung = Antriebsseite

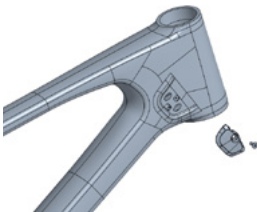

2. Bei Alurahmen entfernen Sie die Abdeckung an der Innenseite der Kettenstrebe.

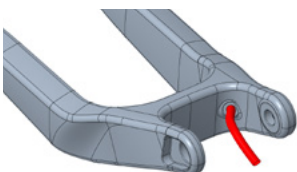
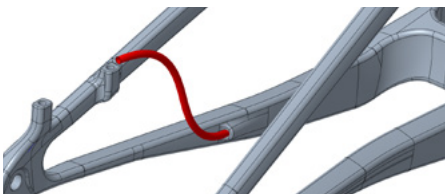

3. Führen Sie den Bremsschlauch (rot) in den Gehäuseanschluss auf der nicht-antriebsseitigen Seite über dem Tretlager ein. Bei Carbonrahmen beachten Sie die Möglichkeit, den hinteren Bremsschlauch für die reguläre oder Moto | UK-AUS-JPN-Variante zu verlegen. Die obere Option ist für die reguläre Verlegung. Die untere Option ist für die Moto-Verlegung.

Reguläre Verlegung = Oberrohr

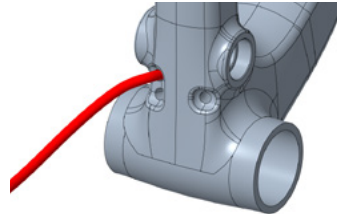

Moto | UK-AUS-Verlegung = Unterrohr.

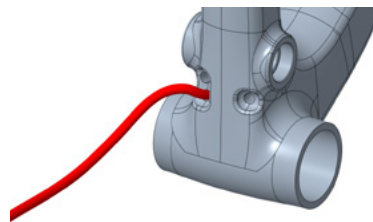

ERSETZEN/INSTALLIEREN DES HINTEREN HYDRAULISCHEN BREMSSCHLAUCHS

4. Drücken Sie den Bremsschlauch von hinten, bis er am Kopfrohranschluss herauskommt.

REGULÄR:

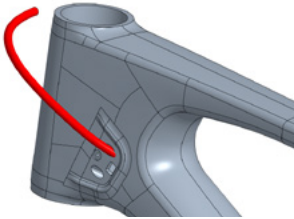

Moto | UK-AUS Routing

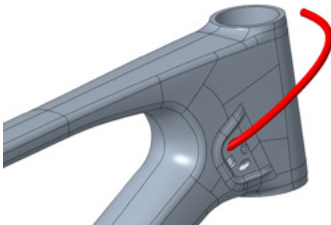

5. Sobald der Bremsschlauch installiert ist, setzen Sie die Abdeckung des Kopfrohranschlusses wieder auf.

REGULÄR:

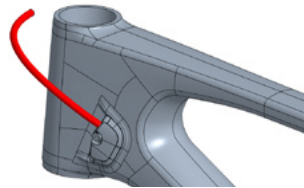

Moto | UK-AUS Routing = Oberrohr

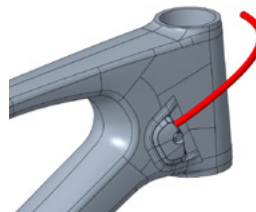

WICHTIGE ABMESSUNGEN



ARTIKELNUM-MER	KATEGORIE	ARTIKEL	MESURE	TEILENUMMER.	BESCHREIBUNG
1	Steuersatz	Steuersatz für Carbonrahmen	FSA No.57e Orbit 1.5ZS		FSA ZS44/56 Headset Commonly referred to as No.57e or Orbit 1.5ZS See Headset chart for information
		Steuersatz für Aluminiumrahmen	FSA No.57e Orbit 1.5ZS		FSA ZS44/56 Headset Commonly referred to as No.57e or Orbit 1.5ZS See Headset chart for information
2	Gabel	Gabelweg	130mm		Compatible with 140mm
		Gabelversatz	27.5" XS = 37 - 44mm		The XS, frame is equipped with 27.5 wheels, but comes with either a 130mm 27.5 or 120mm 29 fork depending on the fork model.
			29" SM - MD - LG - XL = 42 - 44mm		
		Maximale Achse zu Krone Höhe	27.5" XS = 533mm		
			29" SM - MD - LG - XL = 552mm		
3	Stoßdämpfer	Stoßdämpfergröße	XS - SM - MD - LG - XL = 190 x 45mm		
		Stoßdämpfer-Tuning	Siehe Beschreibung		Siehe Stoßdämpfer-Einstellungsdiagramm für Tuning-Informationen.
		Vordere Stoßdämpfer-Befestigungsteile	20 x 8mm		Benötigt benutzerdefinierte Befestigungsteile. Siehe Stoßdämpfer-Befestigungsteile-Diagramm für Informationen.
		Hintere Stoßdämpfer-Befestigungsteile	8 x 40mm	1811007	Benötigt benutzerdefinierte Lageraugen-Befestigungsteile. Siehe Stoßdämpfer-Befestigungsteile-Diagramm für Informationen. Alle Fox Hinterstoßdämpfermodelle außer Float X2. Alle Rock Shox Hinterstoßdämpfermodelle außer Vivid Air. Alle DB Inline-Modelle.
		Genehmigte Stoßdämpfer-Montage	Siehe Beschreibung		Modelle anderer Hersteller von Hinterstoßdämpfern könnten passen, erfordern jedoch eine Montage am Rahmen, um die Abstände bei voller Ausdehnung und Kompression zu überprüfen.
4	Sattelstütze	Innerer Durchmesser des Sitzrohrs.	30.9mm		Für die Größe der Sattelstütze
		Äußerer Durchmesser des Sitzrohrs	34.9mm		Für die Größe der Sattelstützenklemmung
		Minimale Einstecktiefe des Sitzrohrs.	100mm XS = 200 SM = 200		
		Bearbeitete Reibtiefe des Sitzrohrs	MD = 230 LG = 260 XL = 280		Für Informationen zur Sattelstützenmontage siehe den Abschnitt zur Sattelstützenmontage in diesem Handbuch.

WICHTIGE ABMESSUNGEN



ARTIKELNUMMER	KATEGORIE	ARTIKEL	MESURE	TEILENUMMER.	BESCHREIBUNG
		Zahnkranzgrößenbereich	Minimum = 30 Maximum 34T		
		OEM Zahnkranzgröße Kettenlänge	27.5" XS = 32T 116L 29" SM - MD - LG - XL = 32T 118L		
5	Kurbelgarnitur	Kettingenleitkit.	Siehe Beschreibung	1811008	Canadarm 1.0 + OneUp Oberleitungs-Kit Komplettsset
		Kettingenleiter	OneUp Oberleitungsleiter	IC0686	Nur OneUp-Kit
		Bashguard	N/A		
		Innenlager.	vt		
		Kettingenlinie-Bereich	52 - 55mm		Kompatibel mit Sram- und Shimano-Antriebssystemen von 52 bis 55 mm
6	Bremsen	Maximaler Rotor-Durchmesser	203mm		
		Maximale Rotor-Dicke	2.3mm		
7	Rad	Radgröße	XS = 27.5" SM - MD - LG - XL = 29"		Diese Plattform ist nicht MX Mullet-kompatibel
		Maximale Reifenbreite	2.5" 64mm		
		Nabenabstand	12 x 148mm		
8	Hinterradnabe	Hinterachse	12 x 1.0 x 173mm	3222000	Durchmesser 12 mm x Gewindesteigung 1,0 mm x Länge 173 mm
		Komplettes Aufhängungs-Kit	Siehe Beschreibung	1812002	Beinhaltet Aufhängung, Mutter und Unterlegscheibe. Für einzelne Teile siehe Explosionszeichnung
		UDH Transmission	Siehe Beschreibung		Der Rahmen ist UDH- und Transmission-kompatibel

EXPLOSIONSZEICHNUNG

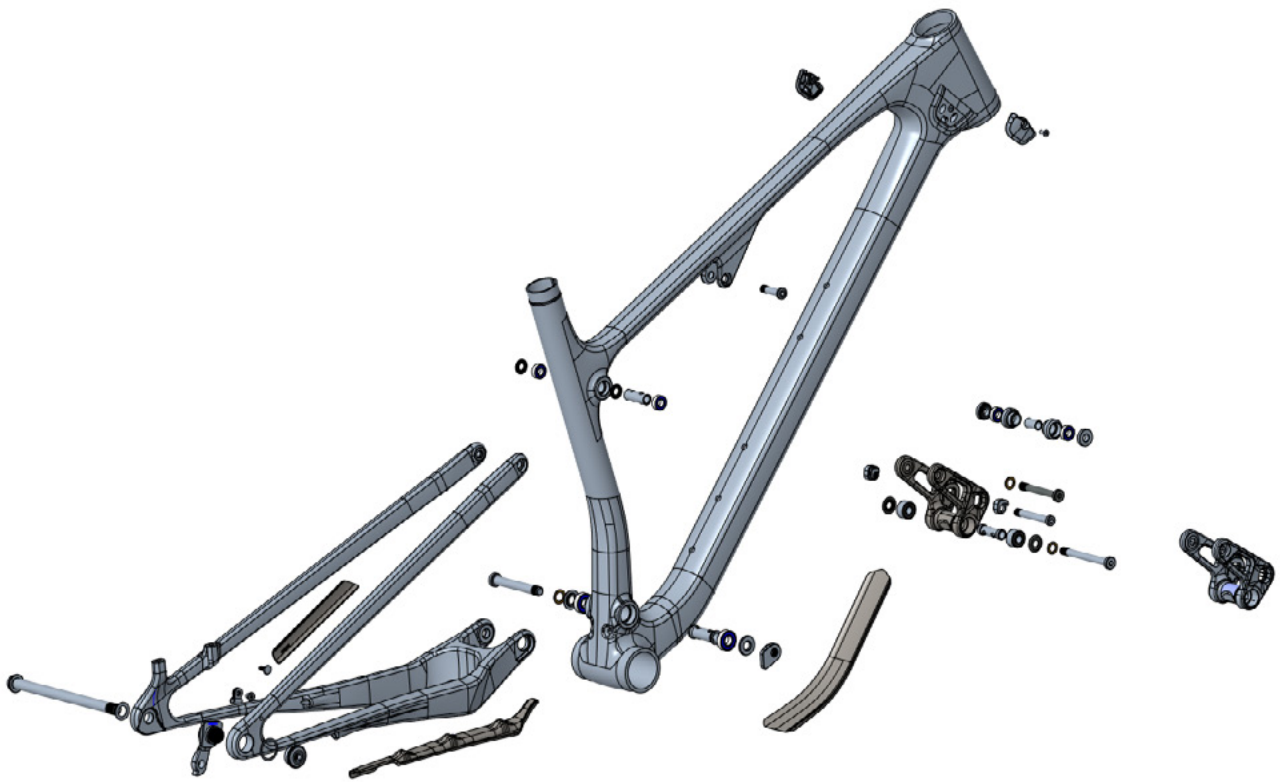

TEILELISTE UND MONTAGEANLEITUNG

2025 ELEMENT CARBON						
#	QTY	ITEM	PART NO.	SUPPLIER	REVISION	DESCRIPTION
			1815078	ZCA013		2025 ELEMENT LINK KIT WITH BEARINGS 29" S-XL
18	1	LINK	1095006			MY25 ELEMENT LINK 29", S-XL, 75MM, 6061-T6, HARD BLACK ANODIZED
3	2	BEARING	1805182			ABI 398LLU MAX, 2RS, 8 X 19, 10/11MM,
31	1	SLEEVE	1805047			LOWER LINK SLEEVE, 36 x 8MM ID, NECKED, 6061-T6, HARD BLACK ANO
			1815079	ZCA013		2025 ELEMENT LINK KIT WITH BEARINGS 27.5" XS
19	1	LINK	1095007			MY25 ELEMENT LINK 27.5", XS, 71.5MM, 6061-T6, HARD BLACK ANODIZED
3	2	BEARING	1805182			ABI 398LLU MAX, 2RS, 8 X 19, 10/11MM,
31	1	SLEEVE	1805047			LOWER LINK SLEEVE, 36 x 8MM ID, NECKED, 6061-T6, HARD BLACK ANO
			1812002			2022 HANGER KIT 12 x1.0
14	1	HANGER	1092003	PTW047		MY22 REAR DER. HANGER, M12X1, UDH COMPATIBLE
15	1	HANGER NUT	1801008	PTW047		RMB UDH HANGER NUT, 7075_T6, HARD BLACK ANODIZED
38	1	WASHER	1801009	PTW047		WASHER, 20X24X0.5MM, 304 SS
			1815080	PTW047		2025 ELEMENT CR PIVOT BOLT KIT
5	1	BOLT	1801005			MP BOLT, M10X1.25, L:75, 6MM HEX
36	2	SPACER	1805183			MAIN PIVOT WASHER, 10MM ID X 22MM OD, 6061-T6, HARD BLACK ANODIZED
37	1	WASHER	1800019			WASHERID: 10.2, OD: 15.5, T:1
20	1	MP CHIP	1802013			MAIN PIVOT CHIP, NO KEY
9	1	BOLT	1805167			UPPER LINK BOLT, 61 x 8MM x M1.0, 7075-T6, HARD BLACK ANODIZED
34	2	SPACER	1800039			DO BEARING SPACER, OD:16, ID:8, T:1.75, 6061 ALU
39	2	WASHER	1802011			WASHER ID: 8.2, OD: 13.5, T: 1
8	1	BOLT	1805046			LINK BOLT LOWER, M8 x 1, L: 80mm, 5mm HEX
35	2	SPACER	1805048			LOWER LINK WASHER, 8MM ID, 18.5MM OD, 6061_T6, HARD BLACK ANODIZED
			1815081	ZCA013		2025 ELEMENT CR PIVOT BEARING KIT
2	2	BEARING	1801010			ENDURO 688 LLU MAX 16X8X5
3	2	BEARING	1805182			ABI 398LLU MAX, 2RS, 8 X 19, 10/11MM,
4	2	BEARING	1807042			ENDURO 6900 2RS MAX 22X10X6
30	1	SLEEVE	1802003			TT BEARING SLEEVE. ID: 8, OD: 11.5, L: 32.4
31	1	SLEEVE	1805047			LOWER LINK SLEEVE, 36 x 8MM ID, NECKED, 6061-T6, HARD BLACK ANO
32	1	SLEEVE	1805187			MAIN PIVOT BEARING SLEEVE, OD:15, ID:10, T:39.5
			1812005	PTW047		SHOCK BOLT KIT ELEMENT 2022
6	1	BOLT	1802007			SHOCK BOLT, M8x1.0, L:31.5, 5mm hex
7	1	BOLT	1802008			RIDE 4 BOLT, M8 x 1, OD: 8 mm, L:56, 5 mm Hex
			1811007	ZCA013		SHOCK BEARING EYELET KIT 2021
2	2	BEARING	1801010	PUS098		ENDURO 688 LLU MAX 16X8X5
33	1	SLEEVE	1807028	PTW047		BEARING EYELET CENTRE SLEEVE
10	2	BRG CUP	1800031	PTW047		BEARING EYELET FOR 16X8X5 BRG
11	2	BRG SPACER	1800032	PTW047		EYELET BEARING SPACER, T:6.3, FOR 40 MM LINK WIDTH
			1812007			AXLE KIT BOOST 12X1.0
1	1	AXLE, REAR	3222000	PTW047		REAR AXLE 12X1.0 L:173MM, HARD BLACK ANODIZE
40	1	WASHER	3227006	PTW047		WASHER, 12x19x0.5MM, 304 SS
			1813467	PTW047		NEW HEAD TUBE PANEL KIT (FROM 2023)
16	1	HT PORT COVER	1803012	PTW047		2023 SLAYER CARBON HT PORT COVER, RIGHT
17	1	HT PORT COVER	1803013	PTW047		2023 SLAYER CARBON HT PORT COVER, LEFT
28	2	SCREW, M4X10	1800024-BK	PTW047		C'SUNK SOCKET SCREW, M4x10MM, 10.9 STEEL, BLACK
			1814029	PTW047		RIDE 4 THREADED 10MM CHIP KIT
25	1	RIDE 4 CHIP	1802009			RIDE 4 CHIP, NO THREAD.
26	1	RIDE 4 CHIP	1802010			RIDE 4 CHIP, THREADED, M8 x 1.

TEILELISTE UND MONTAGEANLEITUNG

		1815082	ZCA013	2025 ELEMENT PROTECTION KIT	
22	1 PROTECTOR	1705001		MY25 ELEMENT CHAINSTAY PROTECTOR, TPE, TEXTURED, 50A	
23	1 PROTECTOR	1705002		MY25 ELEMENT SEATSTAY PROTECTOR, TPE10A,	
24	1 PROTECTOR	3702014		DOWNTUBE PROTECTOR	
		1815083	ZCA013	2025 ELEMENT CR SHIFT HOUSING CLIP KIT	
12	1 CLIP	1992035		CABLE P CLIP, 5MM HOLE	
29	1 SCREW	1804087		LOW-PROFILE HEAD SCREW, HEX, M5 X 0.8, LENGTH 6MM, STAINLESS, ED BLACK	
		1815084	ZCA013	2025 ELEMENT REAR TRIANGLE PLUG KIT	
21	1 PLUG	1804020		M5_RIVNUT_PLUG, BLACK PLASTIC	

LISTE DER KLEINTEILE-SÄTZE

#	QTY	ITEM	PART NO.	TORQUE (Nm)	DESCRIPTION	INSTALLATION NOTES
1	1	AXLE, REAR	3222000	10	REAR AXLE 12X1.0 L:173MM, HARD BLACK ANODIZE	GREASE SHAFT AND THREADS
2	4	BEARING	1801010		ENDURO 688 LLU MAX 16X8X5	
3	2	BEARING	1805182		ABI 398LLU MAX, 2RS, 8 X 19, 10/11MM,	
4	2	BEARING	1807042		ENDURO 6900 2RS MAX 22X10X6	
5	1	BOLT	1801005	12	MP BOLT, M10X1.25, L:75, 6MM HEX	GREASE ON SHAFT, BLUE LOCTITE ON THREADS
6	1	BOLT	1802007	10	SHOCK BOLT, M8x1.0, L:31.5, 5mm hex	GREASE ON SHAFT, BLUE LOCTITE ON THREADS
7	1	BOLT	1802008	8	RIDE 4 BOLT, M8 x 1, OD: 8 mm, L:56, 5 mm Hex	GREASE ON SHAFT, BLUE LOCTITE ON THREADS
8	1	BOLT	1805046	8	LINK BOLT LOWER, M8 x 1, L: 80mm, 5mm HEX	GREASE ON SHAFT, BLUE LOCTITE ON THREADS
9	1	BOLT	1805167	8	UPPER LINK BOLT, 61 x 8MM x M1.0, 7075-T6, HARD BLACK ANODIZED	GREASE ON SHAFT, BLUE LOCTITE ON THREADS
10	2	BRG CUP	1800031		BEARING EYELET FOR 16X8X5 BRG	
11	2	BRG SPACER	1800032		EYELET BEARING SPACER, T:6.3, FOR 40 MM LINK WIDTH	
12	1	CLIP	1992035		CABLE P CLIP, 5MM HOLE	
13	1	FT	1065233CBN		MY25 ELEMENT CARBON FRONT TRIANGLE, LARGE	
14	1	HANGER	1092003		MY22 REAR DER. HANGER, M12X1, UDH COMPATIBLE	
15	1	HANGER NUT	1801008	20	RMB UDH HANGER NUT, 7075_T6, HARD BLACK ANODIZED	BLUE LOCTITE ON THREADS
16	1	HT PORT COVER	1803012		2023 SLAYER CARBON HT PORT COVER, RIGHT	
17	1	HT PORT COVER	1803013		2023 SLAYER CARBON HT PORT COVER, LEFT	
18	1	LINK	1095006		MY25 ELEMENT LINK 29", S-XL, 75MM, 6061-T6, HARD BLACK ANODIZED	
19	1	LINK	1095007		MY25 ELEMENT LINK 27.5", XS, 71.5MM, 6061-T6, HARD BLACK ANODIZED	
20	1	MP CHIP	1802013		MAIN PIVOT CHIP, NO KEY	
21	1	PLUG	1804020		M5_RIVNUT_PLUG, BLACK PLASTIC	
22	1	PROTECTOR	1705001		MY25 ELEMENT CHAINSTAY PROTECTOR, TPE, TEXTURED, 50A	
23	1	PROTECTOR	1705002		MY25 ELEMENT SEATSTAY PROTECTOR, TPE10A,	
24	1	PROTECTOR	3702014		DOWNTUBE PROTECTOR	
25	1	RIDE 4 CHIP	1802009		RIDE 4 CHIP, NO THREAD.	
26	1	RIDE 4 CHIP	1802010		RIDE 4 CHIP, THREADED, M8 x 1.	
27	1	RT	1055231CBN		MY25 ELEMENT CARBON REAR TRIANGLE, SIZE S-XL	
28	2	SCREW	1800024-BK	2	C'SUNK SOCKET SCREW, M4x10MM, 10.9 STEEL, BLACK	DRY
29	1	SCREW	1804087	2	LOW-PROFILE HEAD SCREW, HEX, M5 X 0.8, LENGTH 6MM, STAINLESS, ED BLACK	BLUE LOCTITE ON THREADS
30	1	SLEEVE	1802003		TT BEARING SLEEVE. ID: 8, OD: 11.5, L: 32.4	
31	1	SLEEVE	1805047		LOWER LINK SLEEVE, 36 x 8MM ID, NECKED, 6061-T6, HARD BLACK ANO	
32	1	SLEEVE	1805187		MAIN PIVOT BEARING SLEEVE, OD:15, ID:10, T:39.5	
33	1	SLEEVE	1807028		BEARING EYELET CENTRE SLEEVE	
34	2	SPACER	1800039		DO BEARING SPACER, OD:16, ID:8, T:1.75, 6061 ALU	
35	2	SPACER	1805048		LOWER LINK WASHER, 8MM ID, 18.5MM OD, 6061_T6, HARD BLACK ANODIZED	
36	2	SPACER	1805183		MAIN PIVOT WASHER, 10MM ID X 22MM OD, 6061-T6, HARD BLACK ANODIZED	
37	1	WASHER	1800019		WASHERID: 10.2, OD: 15.5, T:1	
38	1	WASHER	1801009		WASHER, 20X24X0.5MM, 304 SS	
39	2	WASHER	1802011		WASHER ID: 8.2, OD: 13.5, T: 1	
40	1	WASHER	3227006		WASHER, 12x19x0.5MM, 304 SS	

GARANTIE

Für dein Fahrrad besteht eine Garantie für Schäden durch Material- und Verarbeitungsfehler gemäß folgender Tabelle:

KATEGORIE	LAUFZEIT	HINWEISE
Rahmenteile	5 Jahre	Vorderes Rahmendreieck + hinteres Rahmendreieck, Gelenke
Hardware	1 Jahr	Gelenke, Achsen etc.
Verschleißteile des Antriebs	1 Jahr	Kettenräder, Ritzel, Antriebskette
Akku	2 Jahre	Bei Lagerung von über 3 Monaten den Akku alle 3 Monate laden. Nichtbeachtung kann Schäden verursachen.
Komponenten	Gemäß Garantie des Originalherstellers	

Garantiefälle und Kundenservice müssen von dem autorisierten Rocky Mountain Händler durchgeführt werden, der das komplette Fahrrad oder den Rahmen verkauft hat. Wir decken Ihren Rocky Mountain-Rahmen ab dem ursprünglichen Kaufdatum Ihres neuen Fahrrads gegen Material- und Verarbeitungsfehler ab, je nach Rahmenmaterial und der Art der Nutzung des Fahrrads.

Die beschränkte Garantie von Rocky Mountain deckt auch Fahrräder, die zuvor für private und kommerzielle Aktivitäten wie Verleih (einschließlich Fahrradparks), Kurierdienst, Polizeidienst, Sicherheitsdienst usw. verwendet wurden, gegen Material- und Verarbeitungsfehler ab. Die beschränkte Garantie gilt für den Rest der Garantiezeit ab dem ursprünglichen Kaufdatum bei Rocky Mountain. In solchen Fällen sind Hardware, Lager, Drehzapfen und Buchsen von unserer Garantie ausgeschlossen. Der Original-Kaufbeleg, die Bestätigung der Fahrradregistrierung oder ein anderer Kaufnachweis ist für alle Ansprüche erforderlich.

Bei Fahrrädern ab dem Modelljahr 2021 ist die ursprüngliche beschränkte Garantie auf den Zweitbesitzer übertragbar. Die beschränkte Garantie gilt nur dann, wenn sowohl der Erst- als auch der Zweitbesitzer das Fahrrad online registriert haben. Die Originalrechnung ist für den Zweitbesitzer nicht erforderlich.

Bitte registrieren Sie das Fahrrad zur Übertragung der Garantie.

Rahmenmaterial/Art der Nutzung

- Carbonfaser: 5 Jahre – Beschränkt*
- Aluminium: 5 Jahre – Beschränkt*
- Bitte beachten Sie die unten aufgeführten Beschränkungen

Weitere Garantie für Schäden durch Material- und Verarbeitungsfehler

- Beschichtung – Lackierung und Aufkleber: 1 Jahr
- Rahmenhardware, Federung, Gelenke und Buchsen: 1 Jahr
- * Gelenke sind Teil des Rahmens.

bikes.com/registrierung

GARANTIEINFORMATIONEN

HINWEIS

Garantie gilt nicht für Folgendes:

- Einbau und Verwendung von Komponenten, Teilen oder Zubehör, das ursprünglich nicht für das Fahrrad (oder den Rahmen) wie verkauft vorgesehen war oder nicht damit kompatibel ist
- Rocky Mountain Fahrrad wurde nicht von einem autorisierten Händler gekauft
- Rocky Mountain Fahrrad/Rahmen wurde im Internet durch Drittanbieter (z. B. eBay) erworben, unabhängig von den Angaben in der Auflistung
- Ausbleichen der Lackierung aufgrund von ultraviolettem Licht (UV) oder Außenbewitterung fallen nicht unter diese beschränkte Garantie.
- Rocky Mountain übernimmt keine Garantie für Schäden am Fahrrad, die beim Anbringen oder Entfernen von Schutzfilmprodukten entstehen.
- Kratzer oder Steinschläge durch Schmutz, Steine, Fremdkörper, Transport auf Träger etc. fallen nicht unter diese beschränkte Garantie.
- Schäden am Pressfit-Tretlager durch unsachgemäßen Service, Materialien oder Teile sind von der beschränkten Rocky Mountain Garantie nicht abgedeckt.

Einzelheiten dazu, was nicht von der Garantie abgedeckt ist:

- a. Normale Abnutzung und Verschleiß an Reifen, Schläuchen, Bremsen, Schaltzügen, Bremsbelägen, Lagern etc. sind nicht abgedeckt. Ihr autorisierter Rocky Mountain Händler kann genaue Informationen über die Wartung dieser Teile geben.
- b. Schäden, die durch unsachgemäße Nutzung, Unfall, Fehlgebrauch oder Vorsatz entstanden sind
- c. Unsachgemäße Montage oder unterlassene ordnungsgemäße Wartung, Sandstrahlen, Schleifen, Fräsen, Bürsten, Feilen, Schweißen, Löten, das Bohren von Löchern, Eloxieren, Neulackieren oder Verchromen werden von unserer Garantie nicht abgedeckt und können dazu führen, dass die Garantie der anderen Komponenten erlischt.
- d. Neben dem hohen Risiko für Leib und Leben, kann die Herstellergarantie, wie in der Garantie-Tabelle aufgelistet, erlöschen, wenn unsere Produkte in extremem Gelände verwendet werden, wie es zum Teil in Mountainbike Videos gezeigt wird (wie zum Beispiel das Befahren extremer Trails, über Rampen springen, Stunts, BMX Trails befahren, in der Stadt über Treppen und andere Hindernisse fahren oder in ähnlichem Gelände fahren). Es sei darauf hingewiesen, dass verbogene Komponenten wie Rahmenteile, Gabeln, Lenker, Sattelstützen, Pedale, Speichen, etc. als Zeichen von Unfällen oder unsachgemäßer Nutzung angesehen werden können.
- e. Arbeitskosten für den Austausch oder den Wechsel von Teilen sind nicht eingeschlossen.
- f. Rocky Mountain Bicycles behält sich vor, Teile und Komponenten nach eigenem Ermessen als Garantiefall einzustufen und entsprechend zu reparieren oder zu ersetzen. Bitte beachten Sie, dass Rocky Mountain alle Anstrengungen unternimmt, jedoch eine Farbübereinstimmung mit dem ursprünglichen Teil nicht garantieren kann.

GARANTIEAUSSCHLUSS UND HAFTUNGSBESCHRÄNKUNGEN

DIE GARANTIE VON ROCKY MOUNTAIN IST AUF DIE REPARATUR BZW. DEN AUSTAUSCH DER PRODUKTE BESCHRÄNKT UND SCHLIESST KEINE GARANTIE, WEDER AUSDRÜCKLICH NOCH IMPLIZIT, GESETZLICH ODER KONVENTIONELL EIN, UND SCHLIESST JEDLICHE IMPLIZITE GEWÄHRLEISTUNG DER MARKTFÄHIGKEIT UND DER EIGNUNG FÜR BESTIMMTE ZWECKE AUS. ROCKY MOUNTAIN HAFTET UNTER KEINEN UMSTÄNDEN FÜR DIREKTE ODER INDIREKTE, BESTIMMTE, ZUFÄLLIGE ODER FOLGESCHÄDEN, SELBST WENN ROCKY MOUNTAIN ÜBER DIESE SCHÄDEN UNTERRICHTET WURDE. DIE HAFTUNGSSUMME VON ROCKY MOUNTAIN IST AUF 50,00 DOLLAR BESCHRÄNKT.

INTRODUZIONE

L'Element è tutta una questione di efficienza: sarete ispirati a sprintare sulle salite e poi sorpresi dal vostro ritmo nelle discese. Progettata per essere più performante e gestire i singletrack tecnici meglio che mai, la Element trova un equilibrio tra peso, rigidità e comfort. Il design aggiornato delle sospensioni Smoothlink SL e i dettagli del telaio favoriscono una guida precisa, rendendo la Element la bicicletta perfetta per chi corre contro il tempo, per chi insegue un amico o semplicemente per chi si appresta ad affrontare un'altra lunga giornata in sella.

Questo manuale contiene importanti informazioni sulla sicurezza, la manutenzione e l'utilizzo. Leggetelo e comprendetelo a fondo prima della prima uscita con la vostra nuova bicicletta Rocky Mountain. Questo materiale si applica solo alla piattaforma specifica che avete scelto e deve essere utilizzato insieme al Manuale d'uso Rocky Mountain, che è incluso nella vostra bicicletta. Leggere il Manuale d'uso prima della prima uscita. Se non si dispone di una copia del Manuale d'uso, è possibile richiederla al più vicino rivenditore autorizzato Rocky Mountain.

SHREDIQUETTE

Cavalieri

Siate sempre cortesi con gli altri utenti dei sentieri. Prestare particolare attenzione agli animali domestici, come cani e cavalli. Lasciare agli altri utenti del sentiero il diritto di precedenza in ogni situazione, sia in salita che in discesa.

Sentieri

Utilizzate la bicicletta solo su sentieri e percorsi omologati per l'uso della bicicletta. Seguite tutte le leggi e i regolamenti locali. Come per tutti gli utenti dei sentieri, è necessario prestare attenzione ad evitare impatti sul sentiero o sull'ambiente. Non sbandate o modificate i sentieri.

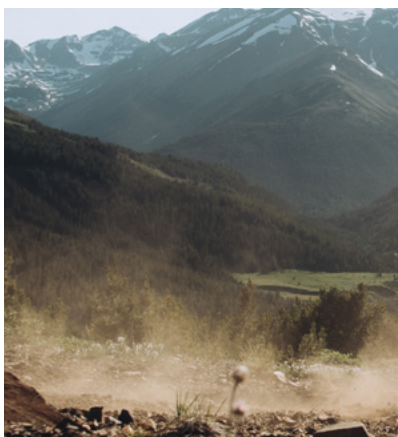
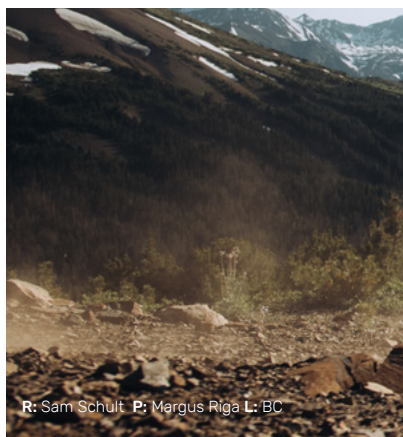

CONOSCERE LA BICICLETTA



DETTAGLI TECNICI

- L'Element aggiornato presenta un telaio dal design completamente nuovo con il nostro nuovo triangolo posteriore flex stay che aumenta la rigidità e riduce drasticamente il peso del telaio.
- Il nuovo cinematismo Smoothlink SL è caratterizzato da una sensibilità abbinata a un maggiore supporto lungo tutta la corsa, con l'obiettivo di aumentare la rigidità per un migliore trasferimento della potenza.
- La geometria progressiva e le accurate caratteristiche del telaio rimangono, garantendo un'esperienza familiare e performante rispetto all'apprezzata generazione precedente.
- Disponibile in un'ampia gamma di misure di telaio e ruote. Il telaio XS è dotato di ruote anteriori e posteriori da 27,5". I telai MD-LG-XL sono dotati di ruote anteriori e posteriori da 29". Questa piattaforma non è destinata a funzionare con la regolazione MX.
- Il sistema di regolazione RIDE-4™ consente ai ciclisti di mettere a punto rapidamente la geometria con una sola chiave a brugola.
- I cuscinetti sigillati sull'occhiello dell'ammortizzatore migliorano notevolmente la sensibilità dell'ammortizzatore e sono compatibili con tutti gli ammortizzatori.
- Le nostre sospensioni Smoothlink SL sono dotate di un triangolo posteriore flex stay che elimina il perno dotato di cuscinetti ai forcellini. Abbiamo poi aggiornato il perno del reggisella con cuscinetti a doppia corona più resistenti e utilizziamo cuscinetti comuni e di facile manutenzione per agevolare gli interventi.
- Sono presenti protezioni per i cuscinetti, comprese le rondelle sigillate sul perno principale, per evitare la contaminazione dovuta alle condizioni dei sentieri accidentati o alle stazioni di lavaggio post corsa.
- Il passaggio interno completamente chiuso sui modelli in carbonio e le ampie porte aperte sui modelli in lega consentono di installare facilmente cavi e tubi, comprese le configurazioni dei freni in stile motociclistico.
- Il dado del perno principale è intercambiabile con quello dell'Instinct per accettare il nostro guidacatena Canadarm OneUp.
- Il telaio è dotato di un pacchetto di protezioni completo, con le nostre protezioni silenziose in gomma per foderi, foderi e tubo obliquo.
- Tutte le misure di telaio, tranne la XS, sono compatibili con due borracce all'interno del triangolo anteriore. Il supporto inferiore della borraccia presenta due posizioni di montaggio per ottimizzare il posizionamento se si preferisce una sola borraccia.

GEOMETRIA E DIMENSIONAMENTO

L'Element è un telaio specifico per la taglia che presenta molti dettagli che migliorano la vestibilità e la geometria per ogni ciclista.

Dimensioni della ruota

- Il telaio XS è dotato di ruote da 27,5" davanti e dietro.
- I telai SM, MD, LG e XL sono dotati di ruote da 29" davanti e dietro.
- Questa piattaforma non è destinata ad essere compatibile con le regolazioni mullet/MX.

Ride-4

Il sistema di regolazione RIDE-4™ consente ai ciclisti di mettere a punto rapidamente la geometria con una sola chiave a brugola da 5 mm. Sono possibili quattro configurazioni grazie a una coppia di chip rotanti. Per sapere come ogni posizione influisce sulla geometria, consultare la tabella delle geometrie. Per le istruzioni di regolazione, consultare la sezione Caratteristiche del telaio.

PRONTI PER OGNI SENTIERO

Il sistema di regolazione RIDE-4™ permette al biker di regolare in modo preciso la geometria e le sospensioni con una chiave a brugola da 5 mm.

ANGOLO DEL CANNOTTO DI STERZO PIÙ ACUTO

SOSPENSIONE MENO PROGRESSIVA

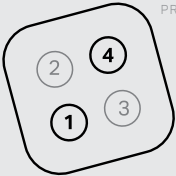

ANGOLO DEL CANNOTTO DI STERZO PIÙ MILD

SOSPENSIONE PIÙ PROGRESSIVA



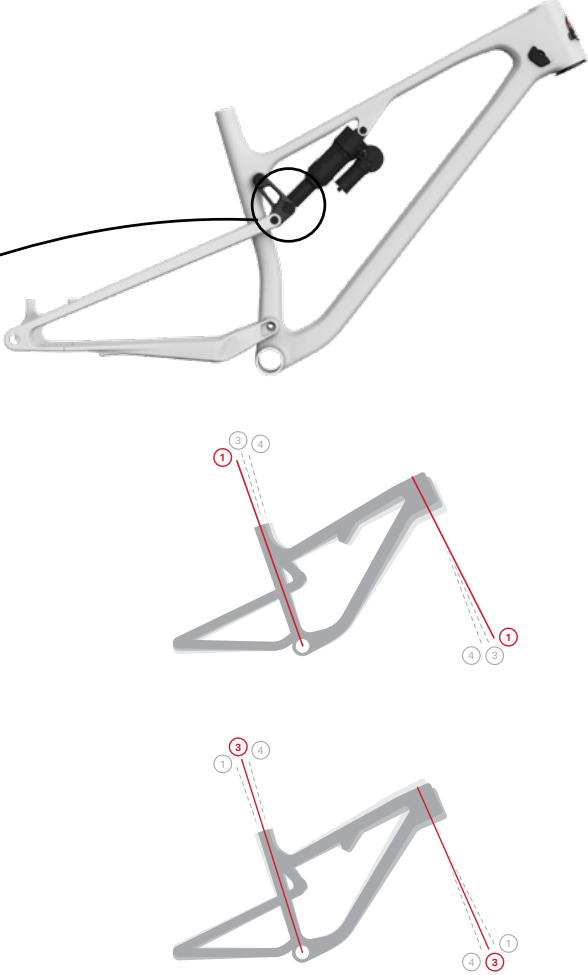

Posizione 1

 APERTA

Il movimento centrale più basso e la sospensione progressiva aumentano la stabilità alle alte velocità. Raccomandata per ciclismo più aggressivo

Posizione 3

 NEUTRA

Questa posizione offre un mix equilibrato di geometria e prestazioni delle sospensioni per adattarsi a una grande varietà di percorsi

Posizione 4

 ACUTA

Il movimento centrale più alto e la sospensione lineare consentono una migliore distanza dai pedali, un tasso di sospensione iniziale più sostenuto e una posizione sulla bicicletta più adatta alla salita.

GEOMETRIA E DIMENSIONAMENTO

Dimensioni del telaio

Questa tabella è solo una guida approssimativa. Le proporzioni del pilota, lo stile di guida e le preferenze personali sono tutti fattori che incidono sulla scelta della misura corretta della bicicletta. In generale, le bici con reach più corto tendono ad avere una sensazione più dinamica e vivace. Le bici più lunghe tendono ad avere una sensazione più stabile e attenuata. Rocky Mountain consiglia sempre di effettuare un test e un montaggio professionale presso un rivenditore autorizzato.

CM	147,5	150	152,5	152,5	155	157,5	160	162,5	165	167,5	170	172,5	175	177,5	180	183	185,5	188	190,5	193	195,5	198
FT-IN	4'7"	4'8"	4'9"	5'0"	5'1"	5'2"	5'3"	5'4"	5'5"	5'6"	5'7"	5'8"	5'9"	5'10"	5'11"	6'	6'1"	6'2"	6'3"	6'4"	6'5"	6'6"
	XS			SM			MD			LG			XL									
XS	████████████████████																					
SM			████████████████████																			
MD					████████████████████																	
LG											████████████████████											
XL																			████████████████████			



R: Celeste Pomerantz P: Niklas Wallner L: Norway

DIAGRAMMA DI GEOMETRIA

MISURA TELAIO	XS	SM	MD	LG	XL
Dimensioni ruote	27.5			29	
Angolo canotto di sterzo (gradi)	64,7	65	65	65	65
Angolo tubo piantone (gradi)	75,7	76	76	76	76
Lunghezza tubo piantone (mm)	355	380	420	445	480
Lunghezza tubo orizzontale (mm)	542	577	605	632	664
Lunghezza canotto di sterzo (mm)	90	105	115	125	135
Interasse posteriore (mm)	426	436	436	436	436
Drop movimento centrale (mm)					
Altezza standover (mm)	769	810	808	806	804
Interasse (mm)	1127	1173	1202	1231	1265
Reach (mm)	397	425	450	475	505
Stack (mm)	561	606	615	624	633

Angolo canotto di sterzo (gradi)	64,9	65,2	65,2	65,2	65,2
Angolo tubo piantone (gradi)	75,9	76,2	76,2	76,2	76,2
Lunghezza tubo piantone (mm)	355	380	420	445	480
Lunghezza tubo orizzontale (mm)	542	577	604	631	663
Lunghezza canotto di sterzo (mm)	90	105	115	125	135
Interasse posteriore (mm)	426	435	435	435	435
Drop movimento centrale (mm)					
Altezza standover (mm)	770	811	809	807	805
Interasse (mm)	1127	1173	1202	1231	1265
Reach (mm)	400	427	452	477	507
Stack (mm)	563	607	616	625	635

DIAGRAMMA DI GEOMETRIA

MISURA TELAIO	XS	SM	MD	LG	XL
Dimensioni ruote	27.5			29	
Angolo canotto di sterzo (gradi)	65,3	65,5	65,5	65,5	65,5
Angolo tubo piantone (gradi)	76,1	76,5	76,5	76,5	76,5
Lunghezza tubo piantone (mm)	355	380	420	445	480
Lunghezza tubo orizzontale (mm)	541	576	603	631	663
Lunghezza canotto di sterzo (mm)	90	105	115	125	135
Interasse posteriore (mm)	425	435	435	435	435
Drop movimento centrale (mm)	21	40	40	40	40
Altezza standover (mm)	771	812	810	809	807
Interasse (mm)	1127	1173	1202	1231	1265
Reach (mm)	403	430	455	480	510
Stack (mm)	565	609	618	627	636
<hr/>					
Angolo canotto di sterzo (gradi)	65,5	65,8	65,8	65,8	65,8
Angolo tubo piantone (gradi)	76,5	76,8	76,8	76,8	76,8
Lunghezza tubo piantone (mm)	355	380	420	445	480
Lunghezza tubo orizzontale (mm)	541	575	603	630	662
Lunghezza canotto di sterzo (mm)	90	105	115	125	135
Interasse posteriore (mm)	425	435	435	435	435
Drop movimento centrale (mm)	19	36	36	36	36
Altezza standover (mm)	772	813	811	810	808
Interasse (mm)	1127	1173	1202	1231	1265
Reach (mm)	405	433	458	483	513
Stack (mm)	566	610	619	628	637

GEOMETRIA E DIMENSIONAMENTO

Montaggio di un reggisella con forcellino

I reggisella con forcellino svolgono un ruolo importante per la vestibilità e il comfort della bicicletta. Di seguito troverete le dimensioni e le misure fondamentali che vi guideranno nella configurazione del reggisella OEM, nonché alcune delle possibili opzioni se viene installato un reggisella aftermarket.

La tabella mostra l'adattamento del reggisella con l'escursione completamente estesa. In questo modo è possibile determinare la posizione più bassa o più alta in cui il reggisella può essere regolato per ottenere l'altezza corretta in una posizione di pedalata da seduti. La tabella vi aiuterà anche a determinare la misura del reggisella da installare se quello OEM non è della misura desiderata. Si prega di notare che la dimensione elencata è dal centro del BB alla parte superiore della sella OEM. La lunghezza della guarnitura può influenzare l'adattamento della sella e deve essere presa in considerazione se si cambia questo componente.

Come utilizzare il grafico

1. Misurate l'altezza attuale della sella dal centro del movimento centrale alla parte superiore della sella, proprio sopra il reggisella.
2. Scegliere il modello di montante desiderato e la quantità di corsa/discesa del montante e del telaio.
3. Assicurarsi che la misura sia compresa tra la lunghezza di inserimento minima e massima indicata nella tabella.

Esempio: Ho misurato 795 mm sulla mia bici attuale. Se scelgo una OneUp V3, con escursione di 210 mm, su un telaio LG Carbon, posso vedere che posso adattarmi a questa combinazione di escursione del montante e dimensioni del telaio, dato che le misure minime e massime possibili sono 728 mm e 860 mm.

MODELLO POSTALE	SPECIFICHE OEM PER TELAIO DIMENSIONI	VIAGGI POSTALI	DIMENSIONI DEL TELAIO	CARBON				
				XS	SM	MD	LG	XL
X Fusion Manic	XS - SM	125	Lunghezza del tubo sella	355	380	420	445	480
			Inserimento minimo	100	100	100	100	100
			Inserimento massimo	200	200	230	260	280
	MD	125	Altezza minima della sella	599	624	640	665	700
		125	Altezza massima della sella	671	696	736	761	796
	LG	150	Altezza minima della sella	663	688	698	693	725
		150	Altezza massima della sella	725	750	790	815	850
	XL	170	Altezza minima della sella	707	732	742	737	752
		170	Altezza massima della sella	739	764	804	829	864
	200	Altezza minima della sella	772	797	807	802	817	
200	Altezza minima della sella	784	809	849	874	909		
2025 Fox Transfer *La corsa è regolabile e può essere ridotta fino a 25 mm, con incrementi di 5 mm.	XS - SM	120	Lunghezza del tubo sella	574	599	621	646	681
		120	Inserimento minimo	646	671	711	736	771
	MD	150	Inserimento massimo	639	664	674	677	712
		150	Altezza minima della sella	711	736	776	801	836
	LG	180	Altezza massima della sella	704	729	739	734	749
		180	Altezza minima della sella	776	801	841	866	901
	XL	210	Altezza massima della sella	769	794	804	799	814
200	210	Altezza minima della sella	841	866	906	931	966	

GEOMETRIA E DIMENSIONAMENTO

MODELLO POSTALE	SPECIFICHE OEM PER TELAIO DIMENSIONI	VIAGGI POSTALI	DIMENSIONI DEL TELAIO	CARBON				
				XS	SM	MD	LG	XL
Reverb AXS *L'inserimento minimo del palo è di 80 mm, ma il telaio richiede 100 mm.	XS - SM	125	Lunghezza del tubo sella	587	612	652	677	712
		125	Inserimento minimo	687	712	752	777	812
	MD	150	Inserimento massimo	637	662	677	702	737
		150	Altezza minima della sella	737	762	802	827	862
	LG - XL	175	Altezza massima della sella	687	712	722	727	762
		175	Altezza massima della sella	787	812	852	877	912
OneUp V3 Dropper *La corsa è rego- labile e può essere ridotta fino a 20 mm, con incrementi di 10 mm.	XS - SM	120	Lunghezza del tubo sella	560	585	625	650	685
		120	Inserimento minimo	645	670	710	735	770
	MD	150	Inserimento massimo	620	645	655	675	710
		150	Altezza minima della sella	705	730	770	795	830
	LG	180	Altezza massima della sella	680	705	715	710	735
		180	Altezza minima della sella	750	775	815	840	875
	XL	210	Altezza massima della sella	740	765	775	770	785
		210	Altezza minima della sella	795	820	860	885	920
		240	Altezza massima della sella	810	835	845	840	855
		240	Altezza minima della sella	850	875	915	940	975
Revive 3 Dropper *La corsa è rego- labile e può essere ridotta fino a 30 mm, a seconda dell'opzione di cor- sa, con incrementi di 5 mm.		125	Lunghezza del tubo sella	581	606	627	652	687
		125	Inserimento minimo	680	705	745	770	805
		160	Inserimento massimo	651	676	686	687	722
		160	Minimum saddle height	730	755	795	820	855
		185	Altezza massima della sella	701	726	736	731	747
		185	Altezza minima della sella	780	805	845	870	905
		213	Altezza massima della sella	766	791	801	796	811
		213	Altezza minima della sella	815	840	880	905	940

SPECIFICHE E DIMENSIONI

ZS44|56 Cuffia a pressione

Tutti i telai sono dotati di cuffie Press-In ZS44|56

Il telaio Carbon Element utilizza calotte della serie sterzo di tipo press-in. Per rimuovere e installare le calotte nel telaio sono necessari strumenti speciali per le serie sterzo. Le serie sterzo per i telai in carbonio sono prodotte da FSA e sono spesso identificate come modello No.57e o Orbit 1.5zs. Utilizzano parti di assemblaggio standard FSA, come i cuscinetti e le piste, per garantire che la sostituzione degli elementi soggetti a usura sia un processo indolore.

Montaggio Cuffia Element Carbon - Alloy

Notes L'Element utilizza una variante con cuscinetti inossidabili e tappo superiore da 5,3 mm della comune serie sterzo FSA No.57e / Orbit 1.5ZS.

QTÀ	ELEMENTO	CODICE SERIALE	DESCRIZIONE
1	Headset	121-0501	FSA Part Number No.57E - Orbit 1.5ZS Headset with standard bearings and 8mm top cap
1	Headset	H018200000E401	FSA Part Number No.57E - Orbit 1.5ZS Headset with stainless bearings and 5.3mm top cap
2	Upper Headtube	N/A	ZS44 Standard
N/A	Lower Headtube	N/A	ZS56 Standard
1	Rubber O-Ring	160-7042	FSA Top Cap Inner Rubber O-Ring
1	Top Cap	161-4430	FSA 5.3mm Top Cap inc. rubber seal
1	Split Race	160-7626	FSA 1 1/8" Headset Compression Ring
1	Bearing	160-6465	FSA Stainless ACB 1 1/8" 36°x45° Bearing
1	Bearing	160-67400E	FSA Stainless ACB 1.5" 36°x45° Bearing
1	Crown Race	160-5536	FSA 1.5" Crown Race

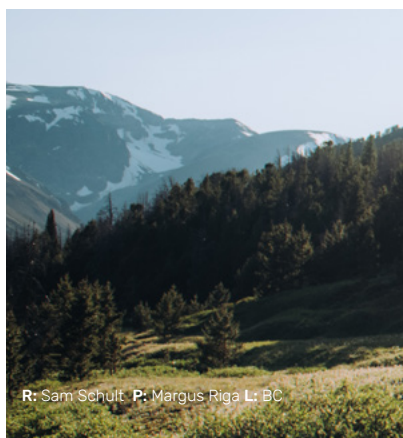

R: Sam Schult. P: Margus Riga L: BC

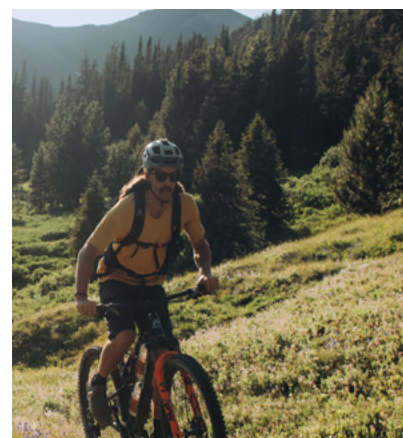

GANCIO UDH

Il vostro nuovo telaio è compatibile con il gancio UDH di Sram. Non ci sono istruzioni speciali relative al telaio che siano necessarie per l'installazione di un gancio UDH. Per una corretta installazione dell'UDH di Sram, consultare le istruzioni di Sram fornite con il gancio.

OCCHIELLO E BULLONERIA DEL CUSCINETTO DELL'AMMORTIZZATORE

Il telaio è dotato di cuscinetti a cartuccia nell'occhiello posteriore, che consentono una migliore aderenza ai piccoli urti. Questi cuscinetti sono sostenuti da coppe che si inseriscono a pressione nello stelo dell'ammortizzatore. In caso di manutenzione dell'ammortizzatore, consigliamo vivamente di rimuovere questi componenti, poiché i centri di assistenza per le sospensioni non possono garantirne la restituzione.

L'hardware dell'ammortizzatore anteriore è un kit standard fornito dal produttore dell'ammortizzatore. Per informazioni tecniche su tutta la viteria dell'ammortizzatore, diagrammi di riferimento e istruzioni per la rimozione del sistema di occhielli dei cuscinetti, consultare la tabella sottostante.

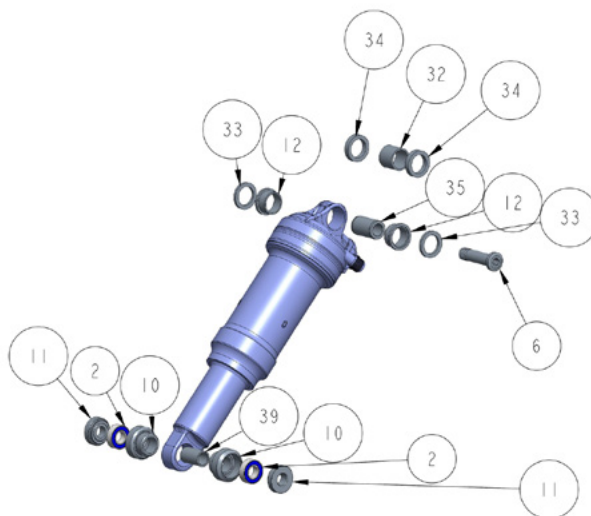

Montaggio Hardware dell'ammortizzatore anteriore dell'elemento
 Dimensioni 20x8 mm (larghezza del perno dell'ammortizzatore x diametro dell'hardware)

QTÀ	ELEMENTO	CODICE SERIALE	DESCRIZIONE
1	Fox Complete Kit	803-03-326	FOX Mounting Hardware - 9 Piece AL 8mm x 20/0.787"
1	Rock Shox Complete Kit	11.4118.091.806	ROCK SHOX HARDWARE 8 x 20.0

Suggerimento professionale: Il kit completo Fox è compatibile con gli occhielli degli ammortizzatori Rock Shox. Rimuovere la boccia in teflon dall'occhiello Rock Shox prima di installare il kit Fox.it.

OCCHIELLO E MINUTERIA CUSCINETTI AMMORTIZZATORE

Rimozione dell'occhiello del cuscinetto

Per rimuovere il sistema, segui questi passaggi:

- Utilizzare il kit di utensili per occhielli ammortizzatori Rocky Mountain (codice# 1810031)
- Installare la calotta copri cuscinetto su un lato dell'occhiello del cuscinetto
- Quindi, installare uno degli strumenti per la rimozione della coppa sopra la coppa del cuscinetto con la calotta copri cuscinetto installato.
- Avvitare saldamente la vite M8 contro la calotta copri cuscinetto
- Installare l'altro strumento di rimozione della coppa sopra l'altra coppa del cuscinetto
- Avvitare la vite M8 fino in fondo fino a quando non inizia a spingere sull'altro lato. È a contatto con l'interno della calotta copri cuscinetto.
- Continuare a infilare fino a quando una delle coppe non è completamente estratta.
- Quindi inserire il punteruolo attraverso l'occhiello dell'ammortizzatore e appoggiarlo saldamente contro la coppa del cuscinetto che è ancora premuta nell'occhiello dell'ammortizzatore.
- Delicatamente, ma con fermezza, martellare il punteruolo fino a rimuovere completamente la coppa del cuscinetto dall'occhiello dell'ammortizzatore.

Se non si dispone del kit di strumenti per occhielli per cuscinetti Rocky Mountain, utilizzare un estrattore per cuscinetti a foro cieco:

- Utilizzare un estrattore per cuscinetti a foro cieco (estensione di 8mm) per rimuovere entrambi i cuscinetti.
- Rimuovere la boccia centrale.
- Utilizzare l'estrattore per cuscinetti a foro cieco (estensione da 10mm) per rimuovere le coppe vuote.

NOTA: il diametro interno delle coppe è di 11 mm, il che significa che l'estensione da 12mm non si adatta (quindi non forzarla); utilizzare l'estensione da 10mm.

Per installare nuove coppe, utilizzare una pressa per cuscinetti o una morsa con ganasce morbide installate, assicurandosi di premere sul bordo esterno delle coppe e non dimenticare la boccia distanziatrice centrale tra le coppe.

CONFIGURAZIONE DELLE SOSPENSIONI

Prima di modificare le impostazioni dell'ammortizzatore, è importante informarsi sulle varie regolazioni che possono essere effettuate.

Regolazione della molla

A seconda del modello di ammortizzatore, potrebbe essere necessario regolare il tasso della molla elicoidale o la pressione dell'aria per ottenere il sag raccomandato per l'Instinct. Consultare la tabella delle molle riportata di seguito per le raccomandazioni sulle velocità delle molle elicoidali e sulle pressioni dell'aria.

Rimbalzo

La regolazione dell'estensione controlla la velocità con cui la sospensione torna alla massima estensione dopo aver colpito un urto. Se il controllo dell'estensione è eccessivo, la forcella o l'ammortizzatore si muoveranno troppo lentamente, affondando sempre di più nella loro corsa in caso di urti ripetuti, con conseguente sensazione di durezza. Troppo poco, e la sospensione può tornare indietro troppo velocemente, causando una perdita di trazione e di controllo.

- L'estensione a bassa velocità (LSR) si riferisce alla bassa velocità della forcella o dell'ammortizzatore, non alla velocità del sentiero. Questa regolazione influisce sulla velocità di estensione nella prima parte dell'escursione. Per comodità, possiamo ipotizzare un'escursione compresa tra lo 0% e il 40%.
- L'High Speed Rebound (HSR) si riferisce alla velocità elevata della forcella o dell'ammortizzatore, non alla velocità del trail. Questa regolazione influisce sulla velocità di estensione nella seconda parte dell'escursione. Per comodità, possiamo ipotizzare un'escursione compresa tra il 40% e il 100%.

Compressione

La regolazione della compressione controlla la velocità con cui la sospensione si muove nella sua corsa quando colpisce un dosso. Se la regolazione della compressione è eccessiva, la forcella o l'ammortizzatore si muoveranno troppo lentamente e la forza dell'impatto dipenderà troppo dal pneumatico e dal corpo per assorbire il movimento. Se la compressione è troppo bassa, la forcella o l'ammortizzatore si muoveranno troppo velocemente e la bicicletta risulterà fiacca e poco reattiva.

La compressione a bassa velocità (LSC) si riferisce alla bassa velocità della forcella o dell'ammortizzatore, non alla velocità della pista. Controlla gli spostamenti del peso del ciclista, il pompaggio attraverso il terreno, le uscite in G e altri input lenti. Una quantità eccessiva di LSC determina una sensazione di guida più dura; una quantità troppo bassa di LSC determina una sensazione di guida troppo morbida e poco reattiva. L'LSC è efficace su tutta la gamma di escursione.

La compressione ad alta velocità (HSC) si riferisce all'alta velocità della forcella o dell'ammortizzatore, non alla velocità del sentiero. Controlla la capacità di assorbire gli impatti di grandi dimensioni, come le rocce squadrate e i colpi di fondo. Una quantità eccessiva di HSC determina una sensazione di guida più dura quando si percorrono sentieri veloci e accidentati con molte asperità di grandi dimensioni; una quantità insufficiente di HSC determina un sostegno insufficiente quando si colpiscono le asperità di grandi dimensioni e potrebbe portare all'utilizzo di tutta l'escursione della sospensione.

Fondo idraulico

Il Bottom Out idraulico (HBO) si riferisce alla resistenza al bottom out che alcuni ammortizzatori possono fornire in combinazione con un regolatore esterno. Questa caratteristica riguarda l'ultimo 20% dell'escursione dell'ammortizzatore ed è utilizzata in caso di forti impatti in cui la bicicletta può andare a fondo corsa.

CONFIGURAZIONE DELLE SOSPENSIONI

Le tabelle seguenti riportano tutte le configurazioni degli ammortizzatori OEM per Element. A causa dell'elevato numero di ammortizzatori compatibili con l'Instinct, non possiamo fornire guide di configurazione per modelli che non rientrano nelle specifiche OEM.

Suggerimenti e trucchi per le sospensioni

Quando mettete a punto le sospensioni, annotate le impostazioni in modo da potervi fare riferimento. Meglio ancora, utilizzate un foglio di calcolo online sul vostro telefono!

La rimozione dell'ammortizzatore sull'Element, con il suo design delle sospensioni Smoothlink SL, è facile ma può richiedere alcuni suggerimenti e trucchi. La differenza principale con il triangolo posteriore Smoothlink SL e il suo design monopezzo è che le sedi sono progettate per essere statiche e fornire una forza elastica pari a 0 al 25% di sag. Quando si rimuove l'ammortizzatore, il triangolo posteriore vuole tornare nella sua posizione naturale di riposo. La reinstallazione dell'ammortizzatore richiede una piccola flessione per allineare tutti gli ultimi bulloni rimasti, sia sul perno della sella che sull'attacco dell'ammortizzatore.

Ecco una guida passo passo per la rimozione. Scendere al pignone piccolo della cassetta e bloccare la gabbia del deragliatore aperta, se possibile.

1. Inserire la scossa nel link.
 - a. I distanziali dell'occhiello del cuscinetto su ciascun lato si staccheranno, quindi assicuratevi di mettere una mano sotto l'area dell'occhiello del cuscinetto per tenerli in posizione.
2. Inserire il bullone dell'ammortizzatore posteriore.
 - a. Se necessario, è possibile rimuovere i trucioli Ride4 su entrambi i lati del collegamento per allineare prima il bullone con l'occhiello del cuscinetto. Una volta una volta che il bullone è inserito per metà nell'occhiello del cuscinetto, allineare il chip Ride4 sarà molto più facile.
3. Installare il bullone dell'ammortizzatore anteriore.
 - a. Questa fase richiede di precaricare delicatamente il triangolo posteriore finché l'occhiello dell'ammortizzatore anteriore non si allinea con il foro di montaggio dell'ammortizzatore.
4. Una volta installati e parzialmente filettati entrambi i bulloni degli ammortizzatori, aggiungere un po' di precarico al triangolo posteriore per assicurarsi che tutto l'hardware sia sistemato in posizione e serrare entrambi i bulloni.
5. Serrare tutta la bulloneria secondo le specifiche. Per maggiori dettagli, consultare il nostro diagramma esploso.

Montaggio *Occhiello del cuscinetto dell'ammortizzatore posteriore Element*

Dimensioni *40x8 mm (larghezza x diametro della ferramenta)*

QTÀ	ELEMENTO	CODICE SERIALE	DESCRIZIONE
1	RMB Complete Kit	1811007	8 x 40mm Shock Bearing Eyelet Kit
2	Bearing	1801010	ENDURO 688 LLU MAX 16X8X5
2	Bearing Cup	1800031	BEARING EYELET FOR 16X8X5 BRG
1	Sleeve	1807028	BEARING EYELET CENTRE SLEEVE
2	Bearing Spacer	1800032	EYELET BEARING SPACER, T:6.3, FOR 40 MM LINK WIDTH
1	Rock Shox Complete Kit	11.4118.091.806	ROCK SHOX HARDWARE 8 x 20.0

Montaggio *Hardware dell'ammortizzatore anteriore dell'elemento*

Dimensioni *20x8 mm (larghezza del perno dell'ammortizzatore x diametro dell'hardware)*

QTÀ	ELEMENTO	CODICE SERIALE	DESCRIZIONE
1	Fox Complete Kit	803-03-326	FOX Mounting Hardware - 9 Piece AL 8mm x 20/0.787"
1	Rock Shox Complete Kit	11.4118.091.806	ROCK SHOX HARDWARE 8 x 20.0

CONFIGURAZIONE DELLE SOSPENSIONI

2025 ELEMENT FOX FLOAT AIR SHOCK

DIMENSIONI AMMORTIZZATORE TUTTE LE DIMENSIONI = 190 X 45 MM

REGOLAZIONE AMMORTIZZATORE XS - SM = NO VOLUME SPACERS, CM, RM, CMF
MD - XL = 0.1 VOLUME SPACER X 1, CM, RF, CMF

NOTES *CONTA I CLIC DA CHIUSO: 0 CLIC = CHIUSO*

PESO DEL CAVALIERE	PRESSIONE	SHOCK SAG	LSR	HSR	LSC	HSC
100lbs 45kg	100psi 6.9bar		10			
110lbs 50kg	110psi 7.6bar		10			
120lbs 55kg	120psi 8.3bar		10 - 9			
130lbs 59kg	130psi 9bar		9			
140lbs 64kg	140psi 9.7bar		9 - 8			
150lbs 68kg	150psi 10.3bar		8			
160lbs 73kg	160psi 11bar		8 - 7		Avvio Aprire Regolare in base alle preferenze	
170lbs 77kg	170psi 11.7bar	Tutte le taglie 12 - 14mm	7	Non disponibile		Non disponibile
180lbs 82kg	180psi 12.4bar		7 - 6			
190lbs 86kg	190psi 13.1bar		6			
200lbs 91kg	200psi 13.8bar		6 - 5			
210lbs 95kg	210psi 14.5bar		5			
220lbs 100kg	220psi 15.2bar		5 - 4			
230lbs 105kg	230psi 15.9bar		4			
240lbs 109kg	240psi 16.5bar		4 - 3			
250lbs 114kg	250psi 17.2bar		3			

2025 ELEMENT ROCK SHOX DELUXE AIR SHOCK

DIMENSIONI AMMORTIZZATORE TUTTE LE TAGLIE = 190 X 45MM

REGOLAZIONE AMMORTIZZATORE XS - MD = 0L0 PRL 32SN
LG - XL = 0L1 PRM 32SN

NOTES *CONTA I CLIC DA CHIUSO: 0 CLIC = CHIUSO*

PESO DEL CAVALIERE	PRESSIONE	SHOCK SAG	LSR	HSR	LSC	HSC
100lbs 45kg	130psi 9bar		6 - 5			
110lbs 50kg	140psi 9.7bar		6 - 5			
120lbs 55kg	150psi 10.3bar		5			
130lbs 59kg	160psi 11bar		5 - 4			
140lbs 64kg	170psi 11.7bar		5 - 4			
150lbs 68kg	180psi 12.4bar		4			
160lbs 73kg	190psi 13.1bar		4 - 3			
170lbs 77kg	200psi 13.8bar	Tutte le taglie 12 - 14mm	4 - 3	Non disponibile	Avvio Aprire Regolare in base alle preferenze	Non disponibile
180lbs 82kg	210psi 14.5bar		3			
190lbs 86kg	220psi 15.2bar		3 - 2			
200lbs 91kg	230psi 15.9bar		3 - 2			
210lbs 95kg	240psi 16.5bar		2			
220lbs 100kg	250psi 17.2bar		2 - 1			
230lbs 105kg	260psi 17.9bar		2 - 1			
240lbs 109kg	270psi 18.6bar		1			
250lbs 114kg	280psi 19.3bar		1 - Chiuso			

CONFIGURAZIONE DELLE SOSPENSIONI

2025 ELEMENT ROCK SHOX SIDLUXE AIR SHOCK

DIMENSIONI AMMORTIZZATORE

TUTTE LE TAGLIE = 190 X 45MM

REGOLAZIONE AMMORTIZZATORE

XS - SM = S1 R81 C27 X8SN
 MD = S1 R85 C30 X8SN
 LG - XL = D1 R85 C33 X8SN

NOTES

CONTA I CLIC DA CHIUSO: 0 CLIC = CHIUSO

PESO DEL CAVALIERE	PRESSIONE	SHOCK SAG	LSR	HBO	LSC	HSC
100lbs 45kg	150psi 10.3bar		7 - 6			
110lbs 50kg	160psi 11bar		7 - 6			
120lbs 55kg	175psi 12bar		7 - 6			
130lbs 59kg	185psi 12.8bar		6 - 5			
140lbs 64kg	195psi 13.4bar		6 - 5			
150lbs 68kg	205psi 14.1bar		6 - 5			
160lbs 73kg	220psi 15.2bar		6 - 5			
170lbs 77kg	230psi 15.9bar	Tutte le taglie 12 - 14mm	5 - 4	Non disponibile	Avvio Aprire Regolare in base alle preferenza	Non disponibile
180lbs 82kg	240psi 16.5bar		5 - 4			
190lbs 86kg	250psi 17.2bar		5 - 4			
200lbs 91kg	265psi 18.3bar		3 - 4			
210lbs 95kg	275psi 19bar		3 - 4			
220lbs 100kg	290psi 20bar		3 - 4			
230lbs 105kg	305psi 21bar		2 - 3			
240lbs 109kg	320psi 22bar		2 - 3			
250lbs 114kg	330psi 22.8bar		2 - 3			

COME FARE PER INSTRADARE I CAVI

Queste sono istruzioni solo per il telaio Element in carbonio.

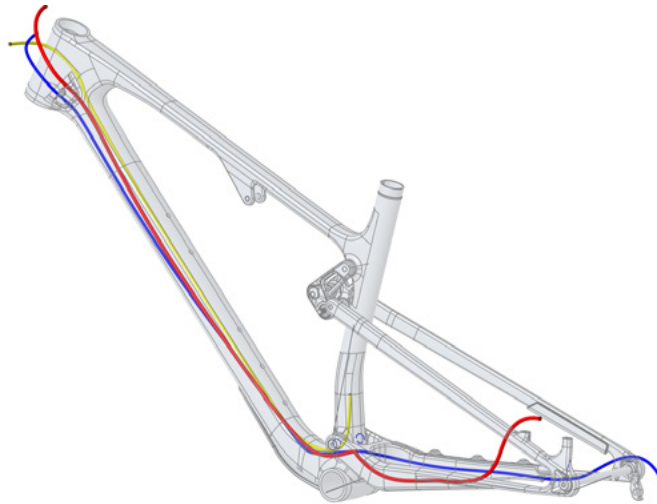

La rimozione della ruota posteriore e del bullone del perno principale consentirà di separare il triangolo posteriore e di accedere meglio all'alloggiamento nell'area tra il triangolo posteriore e quello anteriore.

I canali tubo-tubo nel foderò della catena possono talvolta risultare stretti, soprattutto a causa delle curve che a volte devono percorrere. Spruzzate dell'acqua saponata nell'apertura come lubrificante per facilitare il montaggio dell'alloggiamento da un'estremità all'altra. Non usate grasso o olio, perché sporcano e attirano la sporcizia.

SOSTITUZIONE/INSTALLAZIONE DELL'ALLOGGIAMENTO DEL CAVO DEL DERAGLIATORE POSTERIORE

Se si sostituisce il vecchio alloggiamento, rimuoverlo e tagliare un nuovo pezzo della stessa lunghezza. Se non si dispone del vecchio pezzo, approssimare la lunghezza necessaria e tagliare una parte leggermente più lunga.

- 1.** Rimuovere il coperchio dell'attacco del tubo di testa non lato guida.

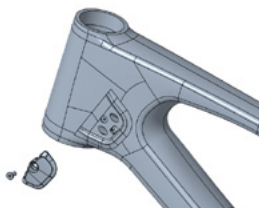

- 2.** Partendo dalla parte posteriore della bicicletta, iniziare a inserire la guaina nell'apertura del cavo sul fodero della catena lato guida. Spingere la guaina in avanti e contemporaneamente ruotarla fino a farla uscire dall'estremità anteriore del fodero della catena.

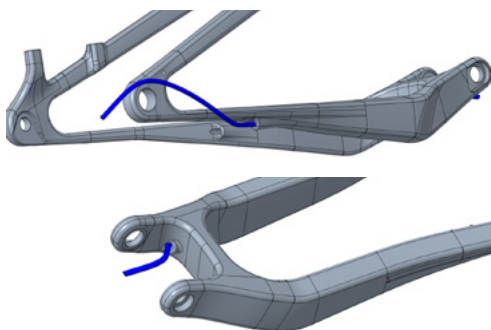

- 3.** Guidare l'alloggiamento nella porta dell'alloggiamento sopra il movimento centrale. Assicurarsi di inserire l'alloggiamento del deragliatore nell'apertura del lato di azionamento.

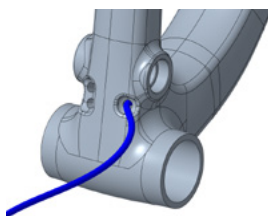

- 4.** Spingere il cavo dalla parte posteriore fino a farlo uscire dall'attacco del tubo di sterzo.

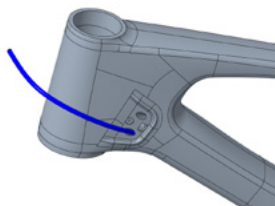

- 5.** Una volta che l'alloggiamento è completamente installato tra il cambio e il deragliatore posteriore, reinstallare l'attacco del tubo di sterzo.

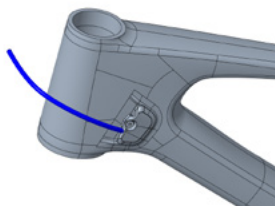

- 6.** Fissare l'alloggiamento del passante posteriore al tubo sella utilizzando la clip a P in plastica e la vite M5.

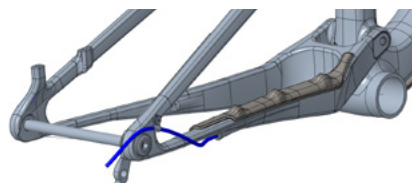

SOSTITUZIONE/INSTALLAZIONE DELLA GUAINA DEL CAVO DEL REGGISELLA

Se si sostituisce il vecchio alloggiamento, rimuoverlo e tagliare un nuovo pezzo della stessa lunghezza. Se non si dispone del vecchio pezzo, approssimare la lunghezza necessaria e tagliare una parte leggermente più lunga.

- 1.** Rimuovere il coperchio dell'attacco del tubo di testa lato guida.

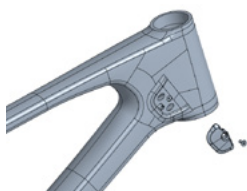

- 2.** Carbonio: partendo dall'attacco del tubo di sterzo, iniziare a introdurre l'alloggiamento nell'apertura della scatola inferiore. Spingere l'alloggiamento in avanti fino a farlo uscire dal tubo sella.

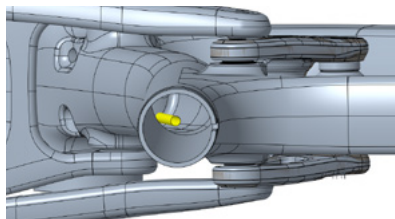
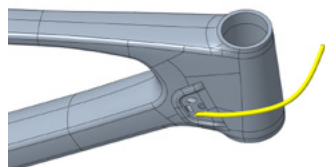

- 3.** Completare l'installazione del forcellino come da istruzioni del produttore del forcellino.

- 4.** Una volta installato correttamente il reggisella, reinstallare l'attacco del tubo di sterzo.

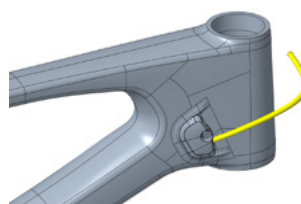

SOSTITUZIONE/INSTALLAZIONE DEL TUBO DEL FRENO IDRAULICO POSTERIORE

1. A seconda della posizione del tubo del freno posteriore, rimuovere il coperchio dell'attacco del tubo di sterzo. il coperchio dell'attacco del tubo di sterzo lato guida o non guida. Se

Instradamento regolare = lato non guida

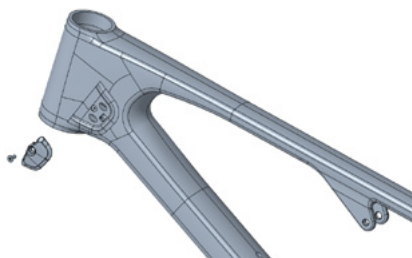

Moto | UK-AUS Percorso = Lato guida

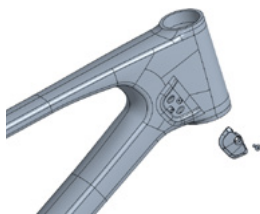

2. Per i telai in lega, rimuovere il coperchio sul lato interno del fodero.

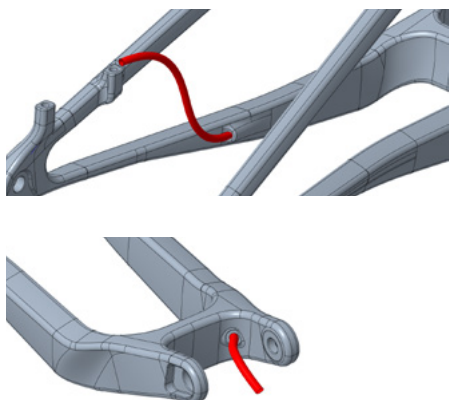

3. Far passare il tubo flessibile del freno (rosso) nell'attacco dell'alloggiamento non lato guida sopra il movimento centrale. Per i telai in carbonio, notare l'opzione di instradamento del tubo del freno posteriore per lo stile normale o Moto | UK-AUS-JPN. L'opzione superiore è per l'instradamento normale. L'opzione inferiore è per il percorso Moto.

Percorso regolare = tubo superiore

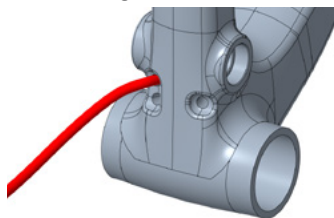

Moto | Percorso UK-AUS = Tubo inferiore

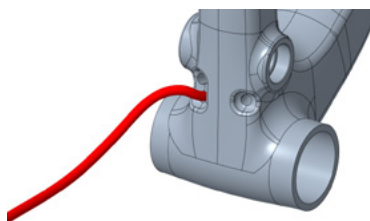

SOSTITUZIONE/INSTALLAZIONE DEL TUBO DEL FRENO IDRAULICO POSTERIORE

4. Quindi spingere il tubo del freno dalla parte posteriore fino a farlo uscire dall'attacco del tubo di sterzo.

REGOLARE:

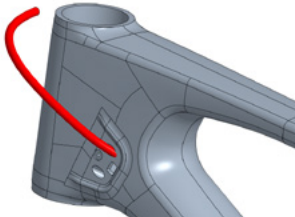

MOTO:

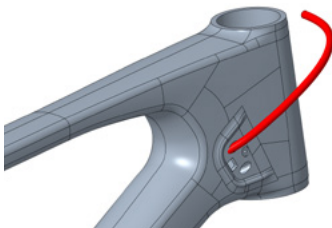

5. Una volta installato il tubo del freno, sostituire il coperchio dell'attacco del tubo di sterzo.

REGOLARE:

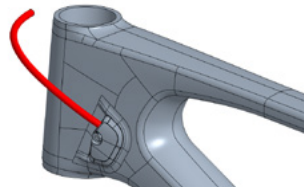

MOTO:

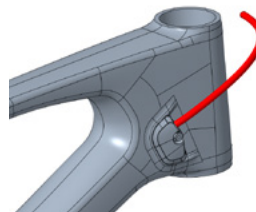

Moto | Percorso UK-AUS = Tubo superiore

DIMENSIONI CRITICHE



NUMERO ELEM-ENTO	CATEGORIA	ELEMENTO	DIMENSIONE	NUMERO PARTE	DESCRIZIONE
1	Headset	Carbon Frame Headset	FSA No.57e Orbit 1.5ZS		FSA ZS44/56 Headset Commonly referred to as No.57e or Orbit 1.5ZS See Headset chart for information
		Alloy Frame Headset	FSA No.57e Orbit 1.5ZS		FSA ZS44/56 Headset Commonly referred to as No.57e or Orbit 1.5ZS See Headset chart for information
2	Fork	Fork Travel	130mm		Compatible with 140mm
		Fork Offset	27.5" XS = 37 - 44mm		The XS, frame is equipped with 27.5 wheels, but comes with either a 130mm 27.5 or 120mm 29 fork depending on the fork model.
			29" SM - MD - LG - XL = 42 - 44mm		
		Maximum Axle to Crown Height	27.5" XS = 533mm		
	29" SM - MD - LG - XL = 552mm				
3	Shock	Shock Size	XS - SM - MD - LG - XL = 190 x 45mm		
		Shock Tune	See Description		Refer to Shock Setup chart for tune information
		Forward Shock Hardware	20 x 8mm		Requires custom hardware. See Shock Hardware chart for information
		Rear Shock Hardware	8 x 40mm	1811007	Requires custom bearing eyelet hardware. See Shock Hardware chart for information
		Approved Shock Fitment	See Description		All Fox rear shock models except Float X2 All Rock Shox rear shock models except Vivid Air All DB Inline models Other rear shock manufacturers' models may fit, but will require fitment on frame to check clearances at full extension and compression
4	Seatpost	Seat Tube Inner Diameter	30.9mm		For seatpost sizing
		Seat Tube Outer Diameter	34.9mm		For seat clamp sizing
		Seat Tube Minimum Insertion	100mm XS = 200 SM = 200		
		Seat Tube Machined Ream Depth	MD = 230 LG = 260 XL = 280		For seatpost fitment information, refer to the seatpost fitment section in this manual

DIMENSIONI CRITICHE



ITEM NUMBER	CATEGORY	ITEM	DIMENSION	PART NUMBER	DESCRIPTION
5	Crankset	Chainring Size Range	Minimum = 30 Maximum 34T		
		OEM Chainring Size Chain Length	27.5" XS = 32T 116L 29" SM - MD - LG - XL = 32T 118L		
	Chain Guide Kit	See Description	1811008	Canadarm 1.0 + OneUp Upper Guide Complete Kit	
	Chain Guide	OneUp Top Guide	IC0686	OneUp kit only	
	Bashguard	N/A			
	Bottom Bracket	PressFit BB92			
6	Brake	Chainline Range	52 - 55mm		Compatible with Sram and Shimano 52 - 55mm drivetrain systems
		Maximum Rotor Diameter	203mm		
		Maximum Rotor Thickness	2.3mm		
7	Wheel	Wheel Size	XS = 27.5"		This platform is not MX Mullet compatible
			SM - MD - LG - XL = 29"		
		Maximum Tire Width	2.5" 64mm		
8	Rear Hub	Hub Spacing	12 x 148mm		
		Rear Axle	12 x 1.0 x 173mm	3222000	Diameter 12mm x Thread Pitch 1.0mm x Length 173mm
		Complete Hanger Kit	See Description	1812002	Includes Hanger, nut, and washer. For individual parts see exploded diagram
		UDH Transmission	See Description		Frame is UDH and Transmission compatible

VISTA ESPLOSA



ELENCO DELLE PARTI E ISTRUZIONI DI MONTAGGIO

2025 ELEMENT CARBON						
#	QTY	ITEM	PART NO.	SUPPLIER	REVISION	DESCRIPTION
			1815078	ZCA013		2025 ELEMENT LINK KIT WITH BEARINGS 29" S-XL
18	1	LINK	1095006			MY25 ELEMENT LINK 29", S-XL, 75MM, 6061-T6, HARD BLACK ANODIZED
3	2	BEARING	1805182			ABI 398LLU MAX, 2RS, 8 X 19, 10/11MM,
31	1	SLEEVE	1805047			LOWER LINK SLEEVE, 36 x 8MM ID, NECKED, 6061-T6, HARD BLACK ANO
			1815079	ZCA013		2025 ELEMENT LINK KIT WITH BEARINGS 27.5" XS
19	1	LINK	1095007			MY25 ELEMENT LINK 27.5", XS, 71.5MM, 6061-T6, HARD BLACK ANODIZED
3	2	BEARING	1805182			ABI 398LLU MAX, 2RS, 8 X 19, 10/11MM,
31	1	SLEEVE	1805047			LOWER LINK SLEEVE, 36 x 8MM ID, NECKED, 6061-T6, HARD BLACK ANO
			1812002			2022 HANGER KIT 12 x1.0
14	1	HANGER	1092003	PTW047		MY22 REAR DER. HANGER, M12X1, UDH COMPATIBLE
15	1	HANGER NUT	1801008	PTW047		RMB UDH HANGER NUT, 7075_T6, HARD BLACK ANODIZED
38	1	WASHER	1801009	PTW047		WASHER, 20X24X0.5MM, 304 SS
			1815080	PTW047		2025 ELEMENT CR PIVOT BOLT KIT
5	1	BOLT	1801005			MP BOLT, M10X1.25, L:75, 6MM HEX
36	2	SPACER	1805183			MAIN PIVOT WASHER, 10MM ID X 22MM OD, 6061-T6, HARD BLACK ANODIZED
37	1	WASHER	1800019			WASHERID: 10.2, OD: 15.5, T:1
20	1	MP CHIP	1802013			MAIN PIVOT CHIP, NO KEY
9	1	BOLT	1805167			UPPER LINK BOLT, 61 x 8MM x M1.0, 7075-T6, HARD BLACK ANODIZED
34	2	SPACER	1800039			DO BEARING SPACER, OD:16, ID:8, T:1.75, 6061 ALU
39	2	WASHER	1802011			WASHER ID: 8.2, OD: 13.5, T: 1
8	1	BOLT	1805046			LINK BOLT LOWER, M8 x 1, L: 80mm, 5mm HEX
35	2	SPACER	1805048			LOWER LINK WASHER, 8MM ID, 18.5MM OD, 6061_T6, HARD BLACK ANODIZED
			1815081	ZCA013		2025 ELEMENT CR PIVOT BEARING KIT
2	2	BEARING	1801010			ENDURO 688 LLU MAX 16X8X5
3	2	BEARING	1805182			ABI 398LLU MAX, 2RS, 8 X 19, 10/11MM,
4	2	BEARING	1807042			ENDURO 6900 2RS MAX 22X10X6
30	1	SLEEVE	1802003			TT BEARING SLEEVE. ID: 8, OD: 11.5, L: 32.4
31	1	SLEEVE	1805047			LOWER LINK SLEEVE, 36 x 8MM ID, NECKED, 6061-T6, HARD BLACK ANO
32	1	SLEEVE	1805187			MAIN PIVOT BEARING SLEEVE, OD:15, ID:10, T:39.5
			1812005	PTW047		SHOCK BOLT KIT ELEMENT 2022
6	1	BOLT	1802007			SHOCK BOLT, M8x1.0, L:31.5, 5mm hex
7	1	BOLT	1802008			RIDE 4 BOLT, M8 x 1, OD: 8 mm, L:56, 5 mm Hex
			1811007	ZCA013		SHOCK BEARING EYELET KIT 2021
2	2	BEARING	1801010	PUS098		ENDURO 688 LLU MAX 16X8X5
33	1	SLEEVE	1807028	PTW047		BEARING EYELET CENTRE SLEEVE
10	2	BRG CUP	1800031	PTW047		BEARING EYELET FOR 16X8X5 BRG
11	2	BRG SPACER	1800032	PTW047		EYELET BEARING SPACER, T:6.3, FOR 40 MM LINK WIDTH
			1812007			AXLE KIT BOOST 12X1.0
1	1	AXLE, REAR	3222000	PTW047		REAR AXLE 12X1.0 L:173MM, HARD BLACK ANODIZE
40	1	WASHER	3227006	PTW047		WASHER, 12x19x0.5MM, 304 SS
			1813467	PTW047		NEW HEAD TUBE PANEL KIT (FROM 2023)
16	1	HT PORT COVER	1803012	PTW047		2023 SLAYER CARBON HT PORT COVER, RIGHT
17	1	HT PORT COVER	1803013	PTW047		2023 SLAYER CARBON HT PORT COVER, LEFT
28	2	SCREW, M4X10	1800024-BK	PTW047		C'SUNK SOCKET SCREW, M4x10MM, 10.9 STEEL, BLACK
			1814029	PTW047		RIDE 4 THREADED 10MM CHIP KIT
25	1	RIDE 4 CHIP	1802009			RIDE 4 CHIP, NO THREAD.
26	1	RIDE 4 CHIP	1802010			RIDE 4 CHIP, THREADED, M8 x 1.

ELENCO DEI KIT DI MINUTERIA

		1815082	ZCA013	2025 ELEMENT PROTECTION KIT
22	1	PROTECTOR 1705001		MY25 ELEMENT CHAINSTAY PROTECTOR, TPE, TEXTURED, 50A
23	1	PROTECTOR 1705002		MY25 ELEMENT SEATSTAY PROTECTOR, TPE10A,
24	1	PROTECTOR 3702014		DOWNTUBE PROTECTOR
		1815083	ZCA013	2025 ELEMENT CR SHIFT HOUSING CLIP KIT
12	1	CLIP 1992035		CABLE P CLIP, 5MM HOLE
29	1	SCREW 1804087		LOW-PROFILE HEAD SCREW, HEX, M5 X 0.8, LENGTH 6MM, STAINLESS, ED BLACK
		1815084	ZCA013	2025 ELEMENT REAR TRIANGLE PLUG KIT
21	1	PLUG 1804020		M5_RIVNUT_PLUG, BLACK PLASTIC

ELENCO DEI KIT DI MINUTERIA

#	QTY	ITEM	PART NO.	TORQUE (Nm)	DESCRIPTION	INSTALLATION NOTES
1	1	AXLE, REAR	3222000	10	REAR AXLE 12X1.0 L:173MM, HARD BLACK ANODIZE	GREASE SHAFT AND THREADS
2	4	BEARING	1801010		ENDURO 688 LLU MAX 16X8X5	
3	2	BEARING	1805182		ABI 398LLU MAX, 2RS, 8 X 19, 10/11MM,	
4	2	BEARING	1807042		ENDURO 6900 2RS MAX 22X10X6	
5	1	BOLT	1801005	12	MP BOLT, M10X1.25, L:75, 6MM HEX	GREASE ON SHAFT, BLUE LOCTITE ON THREADS
6	1	BOLT	1802007	10	SHOCK BOLT, M8x1.0, L:31.5, 5mm hex	GREASE ON SHAFT, BLUE LOCTITE ON THREADS
7	1	BOLT	1802008	8	RIDE 4 BOLT, M8 x 1, OD: 8 mm, L:56, 5 mm Hex	GREASE ON SHAFT, BLUE LOCTITE ON THREADS
8	1	BOLT	1805046	8	LINK BOLT LOWER, M8 x 1, L: 80mm, 5mm HEX	GREASE ON SHAFT, BLUE LOCTITE ON THREADS
9	1	BOLT	1805167	8	UPPER LINK BOLT, 61 x 8MM x M1.0, 7075-T6, HARD BLACK ANODIZED	GREASE ON SHAFT, BLUE LOCTITE ON THREADS
10	2	BRG CUP	1800031		BEARING EYELET FOR 16X8X5 BRG	
11	2	BRG SPACER	1800032		EYELET BEARING SPACER, T:6.3, FOR 40 MM LINK WIDTH	
12	1	CLIP	1992035		CABLE P CLIP, 5MM HOLE	
13	1	FT	1065233CBN		MY25 ELEMENT CARBON FRONT TRIANGLE, LARGE	
14	1	HANGER	1092003		MY22 REAR DER. HANGER, M12X1, UDH COMPATIBLE	
15	1	HANGER NUT	1801008	20	RMB UDH HANGER NUT, 7075_T6, HARD BLACK ANODIZED	BLUE LOCTITE ON THREADS
16	1	HT PORT COVER	1803012		2023 SLAYER CARBON HT PORT COVER, RIGHT	
17	1	HT PORT COVER	1803013		2023 SLAYER CARBON HT PORT COVER, LEFT	
18	1	LINK	1095006		MY25 ELEMENT LINK 29", S-XL, 75MM, 6061-T6, HARD BLACK ANODIZED	
19	1	LINK	1095007		MY25 ELEMENT LINK 27.5", XS, 71.5MM, 6061-T6, HARD BLACK ANODIZED	
20	1	MP CHIP	1802013		MAIN PIVOT CHIP, NO KEY	
21	1	PLUG	1804020		M5_RIVNUT_PLUG, BLACK PLASTIC	
22	1	PROTECTOR	1705001		MY25 ELEMENT CHAINSTAY PROTECTOR, TPE, TEXTURED, 50A	
23	1	PROTECTOR	1705002		MY25 ELEMENT SEATSTAY PROTECTOR, TPE10A,	
24	1	PROTECTOR	3702014		DOWNTUBE PROTECTOR	
25	1	RIDE 4 CHIP	1802009		RIDE 4 CHIP, NO THREAD.	
26	1	RIDE 4 CHIP	1802010		RIDE 4 CHIP, THREADED, M8 x 1.	
27	1	RT	1055231CBN		MY25 ELEMENT CARBON REAR TRIANGLE, SIZE S-XL	
28	2	SCREW	1800024-BK	2	C'SUNK SOCKET SCREW, M4x10MM, 10.9 STEEL, BLACK	DRY
29	1	SCREW	1804087	2	LOW-PROFILE HEAD SCREW, HEX, M5 X 0.8, LENGTH 6MM, STAINLESS, ED BLACK	BLUE LOCTITE ON THREADS
30	1	SLEEVE	1802003		TT BEARING SLEEVE. ID: 8, OD: 11.5, L: 32.4	
31	1	SLEEVE	1805047		LOWER LINK SLEEVE, 36 x 8MM ID, NECKED, 6061-T6, HARD BLACK ANO	
32	1	SLEEVE	1805187		MAIN PIVOT BEARING SLEEVE, OD:15, ID:10, T:39.5	
33	1	SLEEVE	1807028		BEARING EYELET CENTRE SLEEVE	
34	2	SPACER	1800039		DO BEARING SPACER, OD:16, ID:8, T:1.75, 6061 ALU	
35	2	SPACER	1805048		LOWER LINK WASHER, 8MM ID, 18.5MM OD, 6061_T6, HARD BLACK ANODIZED	
36	2	SPACER	1805183		MAIN PIVOT WASHER, 10MM ID X 22MM OD, 6061-T6, HARD BLACK ANODIZED	
37	1	WASHER	1800019		WASHERID: 10.2, OD: 15.5, T:1	
38	1	WASHER	1801009		WASHER, 20X24X0.5MM, 304 SS	
39	2	WASHER	1802011		WASHER ID: 8.2, OD: 13.5, T: 1	
40	1	WASHER	3227006		WASHER, 12x19x0.5MM, 304 SS	

WARRANTY INFORMATION

La bicicletta è garantita contro i difetti di materiale e di fabbricazione come da tabella seguente:

CATEGORIA	PERIODO	NOTES
Parti del telaio	5 anni	Triangolo anteriore + triangolo posteriore, link
Hardware	1 anno	Perni, assi, ecc.
Parti della trasmissione	1 anno	Pulegge, pignoni, catena di trasmissione
Batteria	2 anni	Se conservata per più di 3 mesi, caricare la batteria ogni 3 mesi. La mancata osservanza di questa precauzione può causare danni.
Componenti	Come previsto nella garanzia originale del fabbricante	

Tutti i servizi di garanzia e assistenza post-vendita devono essere gestiti dal rivenditore autorizzato Rocky Mountain che ha venduto il telaio o la bicicletta completa. Il telaio Rocky Mountain è coperto da garanzia contro i difetti di materiale e di fabbricazione a partire dalla data di acquisto della bicicletta nuova, in base al materiale del telaio e al tipo di utilizzo della bicicletta.

La garanzia limitata di Rocky Mountain copre contro i difetti di materiale e fabbricazione anche le biciclette utilizzate in precedenza per attività personali e commerciali, come il noleggio (anche presso i bike park), i servizi di corriere, di polizia, di sicurezza e così via. La garanzia limitata si applica per il periodo di garanzia rimanente a partire dalla data di acquisto originale da Rocky Mountain. In questi casi, minuteria, cuscinetti, perni e bronzine sono esclusi dalla nostra politica di garanzia. Per tutti i reclami è necessario lo scontrino originale, la conferma di registrazione della bicicletta o un'altra prova d'acquisto.

Per i modelli di bicicletta dal 2021 in poi, la garanzia limitata originale è trasferibile ai proprietari di seconda mano. Per la validità della garanzia limitata, la registrazione della bicicletta deve essere effettuata online sia dal proprietario originale che dal proprietario di seconda mano. La fattura originale non sarà richiesta al proprietario di seconda mano.

Per trasferire la garanzia è necessario registrare la bicicletta.

Materiale del telaio / tipo di utilizzo

- Fibra di carbonio: 5 anni - Limitata*
- Alluminio: 5 anni - Limitata*
- Si rimanda alle limitazioni indicate di seguito

Altre coperture in garanzia contro i difetti dei materiali e di fabbricazione

- Rivestimento - vernice e decalcomanie: 1 anno
- Hardware del telaio, sospensioni, perni e bronzine: 1 anno
- * Le maglie fanno parte del telaio.

bikes.com/registration

GARANTIE

NOTA

La garanzia non è valida nei casi seguenti:

- Installazione e utilizzo di componenti, parti o accessori non originariamente previsti o compatibili con la bicicletta o il telaio venduti.
- Acquisto di una bicicletta Rocky Mountain da un rivenditore non autorizzato.
- Acquisto di una bicicletta o di un telaio Rocky Mountain su siti internet di terze parti (come eBay), indipendentemente da quanto indicato nell'inserzione.
- Lo sbiadimento della vernice causato dagli effetti della luce ultravioletta (UV) o dall'esposizione all'esterno non è coperto dalla presente garanzia limitata.
- Rocky Mountain non fornisce alcuna garanzia per eventuali danni causati alla bicicletta durante l'applicazione o la rimozione di qualsiasi pellicola protettiva.
- Graffi o scheggiature della vernice causati da sporczia, sassi, detriti stradali, trasporto su rack, ecc. non sono coperti dalla presente garanzia limitata.
- I danni al movimento centrale Press-fit causati da manutenzione, parti o materiali inadeguati non sono coperti dalla garanzia limitata Rocky Mountain.

Dettagli di cosa non è coperto dalla garanzia:

- A. La normale usura di pneumatici, tubi, freni, cavi del cambio, pastiglie dei freni, cuscinetti, ecc. non è coperta da garanzia. Il rivenditore autorizzato Rocky Mountain informerà il cliente su quali sono queste normali parti soggette a manutenzione.
- B. Danni consequenziali o qualsiasi danno causato da incidenti, uso improprio o abuso.
- C. L'assemblaggio improprio o la mancata manutenzione, la sabbatura, la levigatura, la smerigliatura, la spazzolatura a filo, la limatura, la saldatura, la brasatura, la foratura, l'anodizzazione, la riverniciatura o la cromatura non sono coperti dalla nostra garanzia e possono invalidare la garanzia degli altri componenti.
- D. L'utilizzo della bicicletta su terreni estremamente difficili come quelli che si vedono nei video di mountain bike (piste di trial, rampe, acrobazie, piste di BMX, scale, terrapieni, ecc.) è molto pericoloso e annulla la garanzia descritta nella tabella precedente. È importante notare che la piegatura di componenti, telai, forcelle, manubri, reggisella, pedali, pedivelle e cerchi delle ruote è segno di incidenti o uso improprio.
- E. È esclusa la manodopera per la sostituzione dei componenti.
- F. Rocky Mountain si riserva il diritto di riparare o sostituire a sua discrezione qualsiasi parte considerata validamente coperta da garanzia. Si prega di notare che Rocky Mountain farà tutto il possibile per assicurare la corrispondenza del colore con il componente originale, ma non può garantirla.

ESCLUSIONE E LIMITAZIONE DEI DANNI

LA GARANZIA DI ROCKY MOUNTAIN SI LIMITA ALLA RIPARAZIONE O ALLA SOSTITUZIONE DEI PRODOTTI E NON CONCEDE ALCUNA GARANZIA ESPRESSA O IMPLICITA, LEGALE O CONVENZIONALE E DECLINA QUALSIASI GARANZIA IMPLICITA DI COMMERCIALIZZABILITÀ E IDONEITÀ PER SCOPI PARTICOLARI; ROCKY MOUNTAIN NON SARÀ IN NESSUN CASO RESPONSABILE PER DANNI DIRETTI O INDIRETTI, SPECIALI, INCIDENTALI O CONSEQUENZIALI, ANCHE QUALORA ROCKY MOUNTAIN SIA STATA AVVISATA DI TALI DANNI, E LA RESPONSABILITÀ DI ROCKY MOUNTAIN SARÀ LIMITATA A 50,00 DOLLARI.



LOVE THE RIDE

Development Center
Centre de développement
Entwicklungszentrum
Centro di Sviluppo

1225 East Keith Road, unité 10
North Vancouver (Colombie-Britannique) V7J 1J3
Tél.: 604 980-9938 | Téléc.: 604 980-9975

Head Office
Siège social
Hauptsitz
Sede Centrale

9095, 25^e Avenue
Saint-Georges (Québec) G6A 1A1
Tél.: 1 800 663-2512 | Téléc.: 1 800 570-8356

Rocky Mountain, son logo et ses autres noms commerciaux appartiennent à Rocky Mountain. Certaines technologies sur les produits Rocky Mountain sont brevetées ou en attente de brevets.

©2024 Rocky Mountain®